



EPTABRICKS 2.0 OUTDOOR

ISTRUZIONI D'USO PER L'UTENTE

LEGGERE ATTENTAMENTE E CONSERVARE CON
CURA ASSIEME AL MOBILE
(istruzioni originali)

INSTRUCTIONS POUR L'UTILISATEUR

*LIRE AVEC ATTENTION CE MANUEL ET LE CONSERVER
PRÈS DU MEUBLE AVEC SOIN
(traduction de la notice originale)*

USER INSTRUCTIONS

*READ CAREFULLY AND KEEP WITH THE CABINET
(translation of the original instructions)*

BETRIEBSANLEITUNG FÜR BETREIBER

*SORGFÄLTIG LESEN UND MIT DEM MÖBEL AUFBEWAHREN
(Übersetzung der Originalanweisungen)*

Modello - Modèle - Model Modell - Modelo - Modelo	EPTABRICKS 2.0 OUTDOOR	
Fabbricante - Constructeur - Manufacturer Hersteller - Fabricante - Fabricante	Epta Spa - Via Mecenate, 86 - 20138 Milano (MI) ITALIA Tel. 02/55403211 Telefax 02/55401023	1/27

INDICE

1. Introduzione	2	IT
2. Avvertenze di sicurezza	3	FR
2.1 Avvertenze per gli apparecchi che utilizzano R290 (propano) e R600a (isobutano)	3	EN
2.2 Avvertenze generali	3	DE
2.3 Avvertenze per la Manutenzione del banco	4	ES
2.4 Avvertenze elettriche	5	PT
2.5 Divieti	5	
3. Descrizione generale	6	
3.1 Sezioni	7	
4. Trasporto del banco	10	
5. Condizioni ambientali	11	
6. Condizioni ambientali	12	
7. Caratteristiche tecniche	13	
8. Uso del banco	14	
9. Manutenzione ordinaria	16	
9.1 Pulizia del banco	16	
9.2 Pulizia vaschetta raccolta acqua	16	
10. Indicazioni utente	17	
10.1 Descrizione del banco	17	
10.2 Trasporto e movimentazione	17	
10.3 Ricezione ed immagazzinamento	17	
10.4 Installazione e condizioni ambientali	18	
10.5 Collegamento elettrico	18	
10.6 Caratteristiche tecniche	18	
10.7 Caricamento del prodotto	19	
10.8 Accesso	19	
10.9 Pulizia e manutenzione ordinaria	23	
10.10 Situazioni di emergenza	24	
10.11 Assistenza tecnica	25	
10.12 Smantellamento ed eliminazione	25	
11. Avvertenze generali integrative	27	

SIMBOLOGIA UTILIZZATA

Simbolo divieto: vieta di effettuare determinate operazioni.



Simbolo attenzione: norme antinfortunistiche per l'operatore.



Simbolo avvertenze: esiste la possibilità di arrecare danno alla porta frigorifera e/o ai suoi componenti.



Simbolo nota: fornisce informazioni utili.

Modello - Modèle - Model Modell - Modelo - Modelo	EPTABRICKS 2.0 OUTDOOR	 Epta
Fabbricante - Constructeur - Manufacturer Hersteller - Fabricante - Fabricante	Epta Spa - Via Mecenate, 86 - 20138 Milano (MI) ITALIA Tel. 02/55403211 Telefax 02/55401023	2/27

1. INTRODUZIONE

Si raccomanda di leggere attentamente il contenuto del presente Manuale e conservarlo unitamente al banco stesso.

Il costruttore declina ogni responsabilità per danni causati a persone o cose dovuti alla mancata osservanza delle avvertenze contenute in questo Manuale.



Fig. 1

Il presente Manuale contiene informazioni ritenute necessarie per il buon uso e funzionamento del banco.

Al suo interno si trovano le seguenti descrizioni e informazioni:

- una descrizione funzionale del banco e di ogni sua parte
- informazioni sulla sicurezza del banco e le regole antinfortunistiche da seguire
- un corretto utilizzo del banco
- una corretta manutenzione ordinaria e programmata, comprese le operazioni di pulizia

Per la corretta installazione del banco si faccia riferimento ai seguenti documenti:

- Quick Reference Instructions

Il presente Manuale è rivolto alle seguenti figure professionali:

- **OPERATORE QUALIFICATO** persona qualificata, istruita per il funzionamento, la regolazione, la pulizia e la manutenzione ordinaria del banco
- **TECNICO SPECIALIZZATO** tecnico addestrato e autorizzato dall'ente indicato nel contratto (costruttore/concessionario/distributore) a eseguire: installazione, manutenzione straordinaria, riparazione, sostituzione e revisione del banco

Le istruzioni d'uso sono disponibili anche su: www.eptarefrigeration.com.

Fare riferimento alla dichiarazione di conformità per le normative e le certificazioni del banco.

Conservare sempre il libretto d'istruzione e in caso di vendita dell'apparecchio consegnarlo al nuovo proprietario.

Modello - Modèle - Model Modell - Modelo - Modelo	EPTABRICKS 2.0 OUTDOOR	
Fabbricante - Constructeur - Manufacturer Hersteller - Fabricante - Fabricante	Epta Spa - Via Mecenate, 86 - 20138 Milano (MI) ITALIA Tel. 02/55403211 Telefax 02/55401023	3/27

2. AVVERTENZE DI SICUREZZA

2.1 Avvertenze per gli apparecchi che utilizzano R290 (propano) e R600a (isobutano)

 L'isobutano e il propano sono gas naturali senza effetti sull'ambiente, ma infiammabili. È quindi indispensabile accertarsi che tutti i tubi del circuito refrigerante non siano danneggiati, prima di collegare il banco alla rete di alimentazione. Il locale in cui viene installato il banco deve disporre di un volume minimo di 1m³ per ogni 8g di refrigerante. La quantità di refrigerante del banco è indicata sulla targa dati tecnici posta sul banco. In caso di perdita di refrigerante, evitare che fiamme libere o fonti di accensione vengano a trovarsi in prossimità del punto di fuga.

 Non danneggiare il circuito refrigerante.

 Al fine di ridurre i rischi connessi all'infiammabilità, l'installazione di questo apparecchio non deve essere effettuata se non da personale adeguatamente qualificato.

 Non danneggiare le pareti interne o esterne dell'apparecchio: il circuito del fluido refrigerante potrebbe danneggiarsi. In caso di pareti danneggiate non avviare l'apparecchio e rivolgersi ad un centro assistenza.

2.2 Avvertenze generali

 Il costruttore declina ogni responsabilità per danni causati a persone o cose dovuti alla mancata osservanza delle avvertenze contenute in questo manuale. Qualsiasi persona utilizzi questo banco dovrà leggere il presente manuale d'uso.

 Il datore di lavoro deve istruire il personale sui rischi da infortuni, sui dispositivi predisposti per la sicurezza del personale, sui rischi di emissione di rumore e sulle regole antinfortunistiche generali previste dalle norme in vigore.

 Il banco deve essere utilizzato da persone adulte in possesso della conoscenza necessaria e le cui capacità fisiche, sensoriali o mentali non siano ridotte; il banco non è concepito per l'utilizzo da parte di minori (in particolare da 0 a 3 anni). I bambini, comunque sotto la sorveglianza e la responsabilità di adulti, non devono giocare con il banco.

 Ogni altro uso non esplicitamente indicato in questo manuale è da considerarsi pericoloso ed il costruttore non può essere ritenuto responsabile per eventuali danni derivanti da uso improprio, erroneo ed irragionevole.

 Il banco deve essere utilizzato da personale dotato degli opportuni dispositivi di protezione individuali.

 È obbligatorio l'uso di guanti da lavoro.

 Non lasciare esposto il banco agli agenti atmosferici.

 Non utilizzare getti d'acqua diretti o indiretti sul banco.

 Non toccare il banco con mani e piedi bagnati o umidi, non usare il banco a piedi nudi.

IT

FR

EN

DE

ES

PT

Modello - Modèle - Model Modell - Modelo - Modelo	EPTABRICKS 2.0 OUTDOOR	
Fabbricante - Constructeur - Manufacturer Hersteller - Fabricante - Fabricante	Epta Spa - Via Mecenate, 86 - 20138 Milano (MI) ITALIA Tel. 02/55403211 Telefax 02/55401023	4/27

User manual

IT
FR
EN
DE
ES
PT

 La rimozione di protezioni o pannellature che richiedono l'uso di utensili per essere rimosse è riservata esclusivamente al personale qualificato.

 Questo banco è progettato per l'utilizzo, il trasporto e l'immagazzinamento fino ad un'altitudine massima di 2000 m sul livello del mare.

 Per il montaggio di accessori opzionali dedicati, rivolgersi al più vicino centro di assistenza autorizzato.

 Ogni intervento deve essere eseguito esclusivamente da personale qualificato e, in ogni caso, prima di ogni intervento si deve scollegare l'alimentazione elettrica del banco.

 Istruire chiunque usi il banco sulla posizione dell'interruttore sezionatore.

 Gli interventi sul termostato sono riservati esclusivamente al personale tecnico di assistenza.

 Prestare attenzione alle parti calde o in movimento contrassegnate con l'apposito simbolo.

 In caso di incendio, non usare acqua per spegnere le fiamme ma solo estintori a secco.

 L'apparecchio deve essere posizionato in piano.

 Evitare fuochi o scintille all'interno dell'apparecchio.

 Mantenere libere da ostruzioni le aperture di ventilazione nell'involucro dell'apparecchio.

 Non utilizzare apparecchi elettrici all'interno degli scomparti dell'apparecchio per la conservazione dei cibi congelati se questi non sono del tipo raccomandato dal costruttore.

 Non conservare sostanze esplosive o pericolose, quali contenitori sotto pressione con propellente infiammabile, in questo apparecchio.

 Non lasciare pesi sopra il tetto del banco; è opportuno evitare di poggiare le derrate non imballate direttamente sui ripiani, ma utilizzare idonei contenitori per alimenti.

 Non posizionare contenitori di liquido e non versare liquidi sul banco.

2.3 Avvertenze per la Manutenzione del banco

 L'accesso a parti elettriche e/o parti che richiedono l'utilizzo di utensili è riservato a tecnici specializzati.

 Prima di qualsiasi operazione di manutenzione e pulizia riservate all'utente, togliere tensione al banco tramite l'interruttore sezionatore generale a parete.

 Prestare attenzione alle parti calde o in movimento contrassegnate con l'apposito simbolo.

 È obbligatorio l'uso di guanti da lavoro.

Modello - Modèle - Model Modell - Modelo - Modelo	EPTABRICKS 2.0 OUTDOOR	
Fabbricante - Constructeur - Manufacturer Hersteller - Fabricante - Fabricante	Epta Spa - Via Mecenate, 86 - 20138 Milano (MI) ITALIA Tel. 02/55403211 Telefax 02/55401023	5/27

2.4 Avvertenze elettriche

 Accertarsi che la tensione di alimentazione corrisponda ai dati di targa del banco.

 L'installazione elettrica deve essere eseguita a regola d'arte da tecnici specializzati.

 La rimozione della copertura del quadro elettrico è riservata a tecnici specializzati.

 Conformemente alle regole di installazione, la rete di alimentazione deve includere un dispositivo per la disconnessione onnipolare, che assicuri la disconnessione completa dalla rete nelle condizioni della categoria di sovratensione III.

 L'installazione del banco deve essere effettuata secondo le istruzioni del costruttore, da personale professionalmente qualificato e conformemente alle norme sugli impianti elettrici vigenti nei singoli Paesi.

 Un'errata installazione del banco può causare danni a persone, animali o cose, nei confronti dei quali il costruttore non può essere considerato responsabile.

 Se il cavo di alimentazione è danneggiato, deve essere sostituito da personale tecnico di assistenza autorizzato. Non tentare la riparazione del cavo.

 Non alimentare il banco se è danneggiato. In caso di dubbi, contattare il servizio di assistenza o il rivenditore.

 Dopo aver installato il banco assicuratesi che non poggi sul cavo d'alimentazione.

 Per il collegamento non utilizzare assolutamente riduzioni, prolunghie, adattatori o prese multiple. Il collegamento deve avvenire pertanto in maniera DIRETTA alla rete di alimentazione.

2.5 Divieti

 È fatto divieto di utilizzare dispositivi oltre a quelli forniti nel banco dal produttore, per accelerare il processo di sbrinamento.

 È fatto divieto, da parte di personale non specializzato, di rimuovere la copertura del quadro elettrico o aprire pannellature che richiedano l'utilizzo di utensili.

 È fatto divieto di utilizzare il banco per la conservazione e/o l'esposizione di sostanze esplosive, infiammabili o corrosive, come ad esempio bombolette spray con un propellente infiammabile.

 È fatto divieto di utilizzare il banco per la conservazione e/o l'esposizione di prodotti farmaceutici.

 È fatto divieto, in caso di PRODOTTI NON CONFEZIONATI O CONSERVATI A BASSA TEMPERATURA, di utilizzare il banco per la conservazione e/o l'esposizione di bottiglie ed imballi in vetro.

 È fatto divieto di collocare il banco in ambienti in cui sono presenti sostanze gassose esplosive.

 È fatto divieto di rimuovere la targa matricolare del banco.

 È fatto divieto di salire sul banco o sul batticarrello del banco.

IT

FR

EN

DE

ES

PT

Modello - Modèle - Model Modell - Modelo - Modelo	EPTABRICKS 2.0 OUTDOOR	 Epta
Fabbricante - Constructeur - Manufacturer Hersteller - Fabricante - Fabricante	Epta Spa - Via Mecenate, 86 - 20138 Milano (MI) ITALIA Tel. 02/55403211 Telefax 02/55401023	6/27

User manual

IT
FR
EN
DE
ES
PT

3. DESCRIZIONE GENERALE

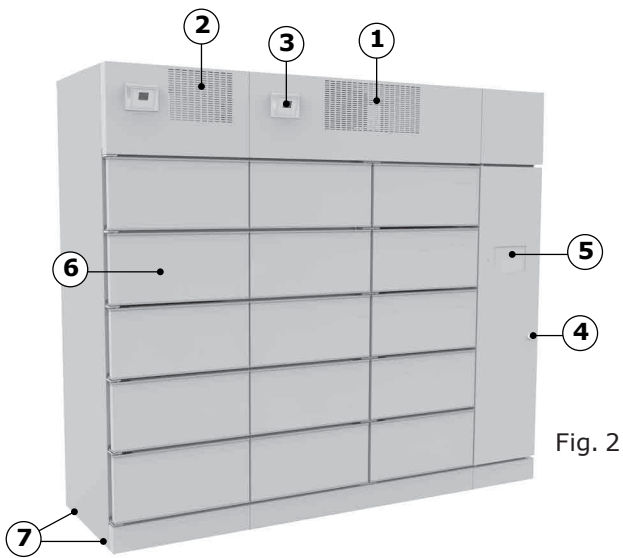

Fig. 2

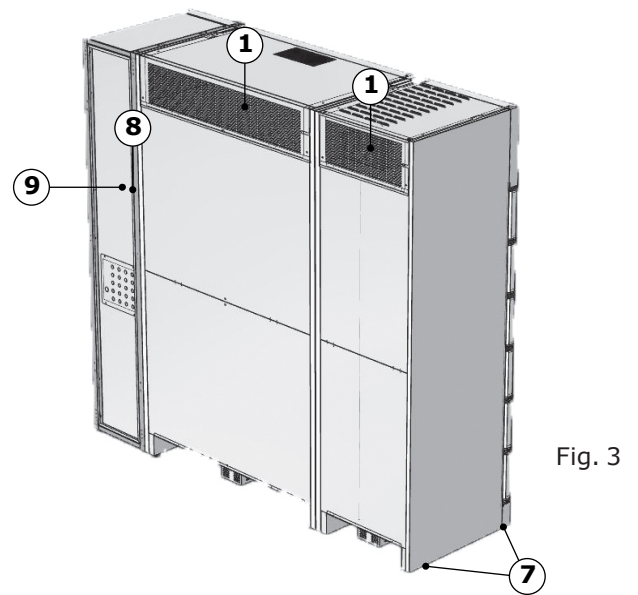

Fig. 3

1. Vano motore
2. Copertura anteriore
3. Centralina elettronica
4. Serratura
5. Display e Lettore QR code
6. Sportelli
7. Piedini regolabili
8. Cavo antenna
9. Cavo alimentazione

Modello - Modèle - Model Modell - Modelo - Modelo	EPTABRICKS 2.0 OUTDOOR	
Fabbricante - Constructeur - Manufacturer Hersteller - Fabricante - Fabricante	Epta Spa - Via Mecenate, 86 - 20138 Milano (MI) ITALIA Tel. 02/55403211 Telefax 02/55401023	7/27

3.1 Sezioni

EPTABRICKS OUTDOOR BT 5 DOORS

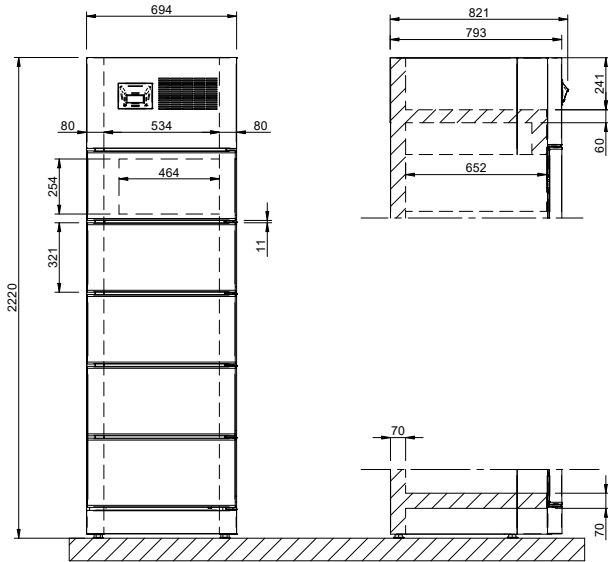

Fig. 4

EPTABRICKS OUTDOOR BT 6 DOORS

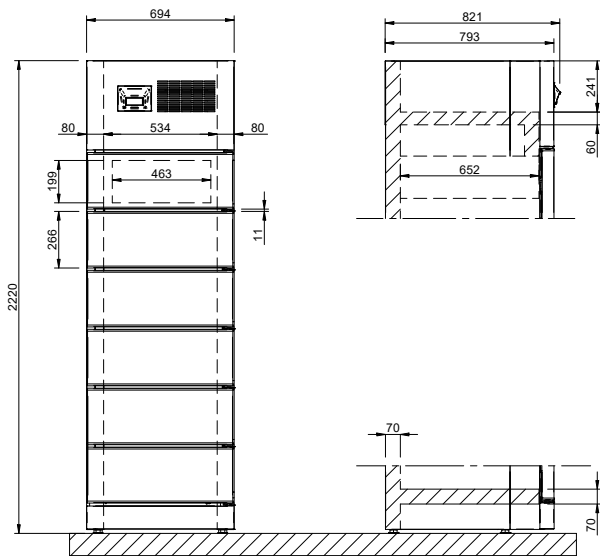

Fig. 5

EPTABRICKS OUTDOOR TN-AMBIENT 6 DOORS

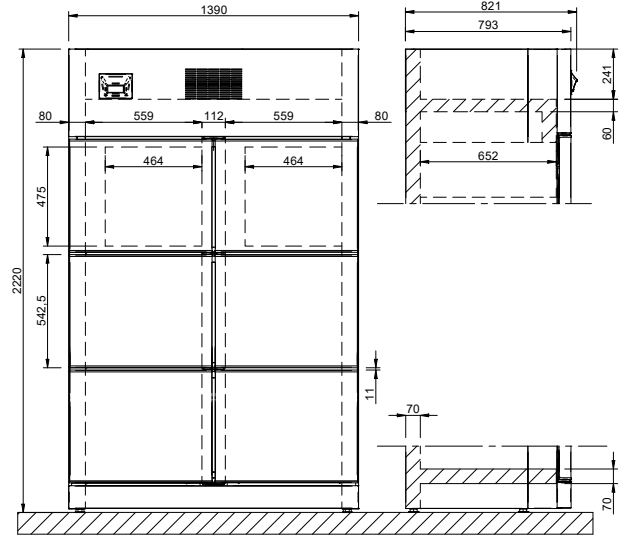

Fig. 6

EPTABRICKS OUTDOOR TN-AMBIENT 8 DOORS

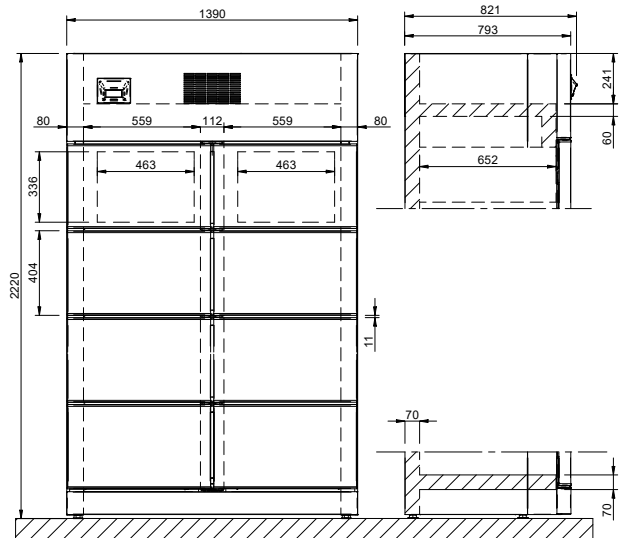

Fig. 7

Modello - Modèle - Model Modell - Modelo - Modelo	EPTABRICKS 2.0 OUTDOOR	
Fabbricante - Constructeur - Manufacturer Hersteller - Fabricante - Fabricante	Epta Spa - Via Mecenate, 86 - 20138 Milano (MI) ITALIA Tel. 02/55403211 Telefax 02/55401023	8/27

User manual

- IT
- FR
- EN
- DE
- ES
- PT

EPTABRICKS OUTDOOR TN-AMBIENT 10 DOORS EPTABRICKS OUTDOOR DRY 8 DOORS

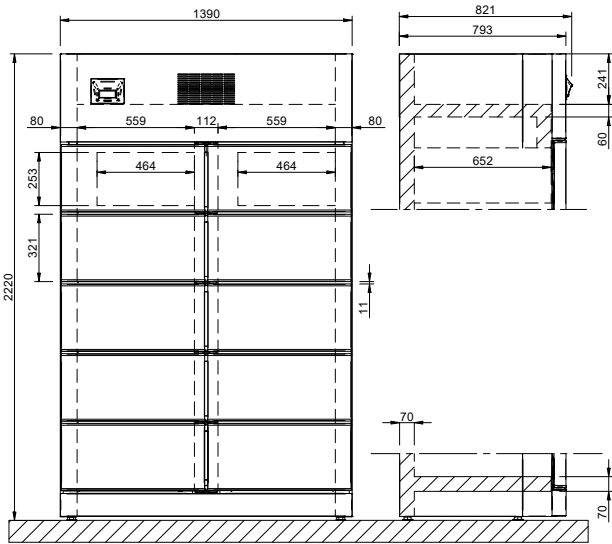

Fig. 8

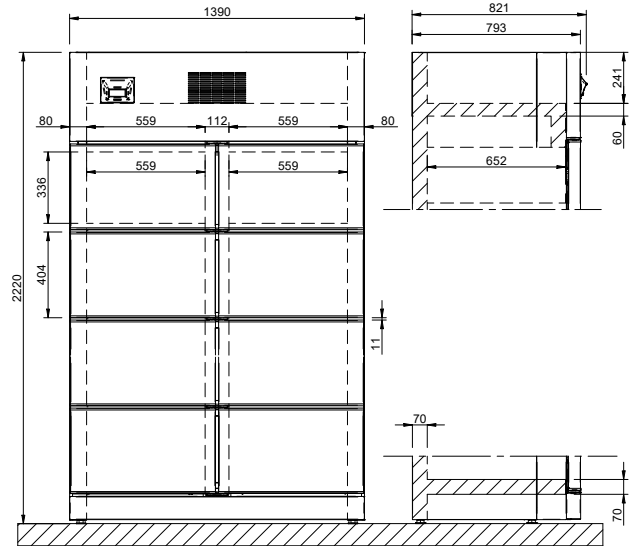

Fig. 10

EPTABRICKS OUTDOOR DRY 6 DOORS

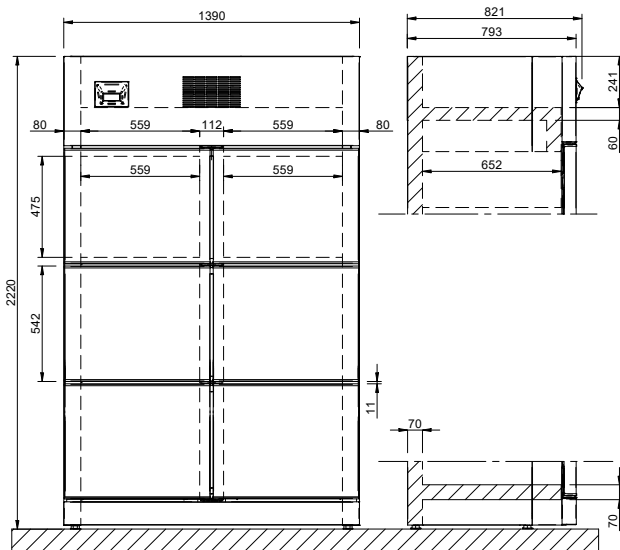

Fig. 9

EPTABRICKS OUTDOOR DRY 10 DOORS

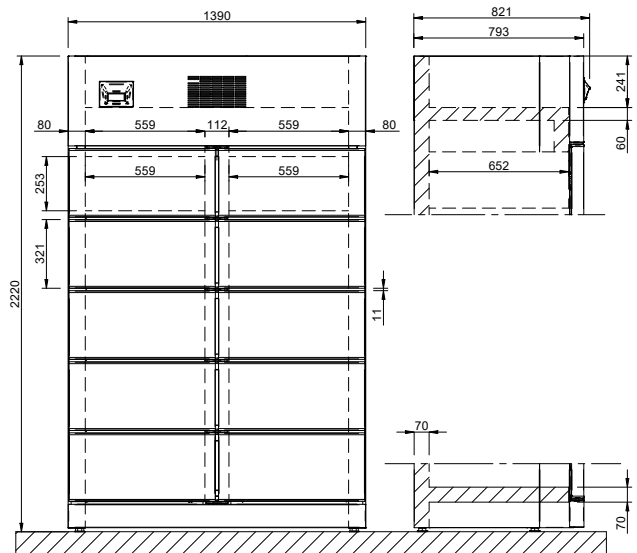

Fig. 11

Modello - Modèle - Model Modell - Modelo - Modelo	EPTABRICKS 2.0 OUTDOOR	
Fabbricante - Constructeur - Manufacturer Hersteller - Fabricante - Fabricante	Epta Spa - Via Mecenate, 86 - 20138 Milano (MI) ITALIA Tel. 02/55403211 Telefax 02/55401023	9/27

EPTABRICKS OUTDOOR MASTER

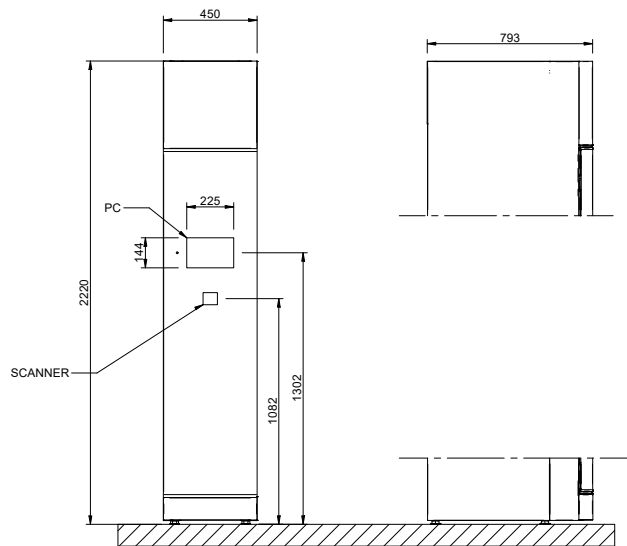

Fig. 12

IT

FR

EN

DE

ES

PT

Modello - Modèle - Model Modell - Modelo - Modelo	EPTABRICKS 2.0 OUTDOOR	
Fabbricante - Constructeur - Manufacturer Hersteller - Fabricante - Fabricante	Epta Spa - Via Mecenate, 86 - 20138 Milano (MI) ITALIA Tel. 02/55403211 Telefax 02/55401023	10/27

User manual

4. TRASPORTO DEL BANCO

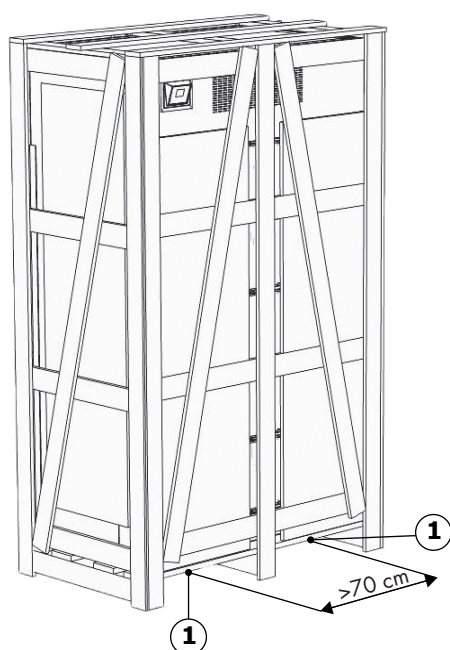

Fig. 13

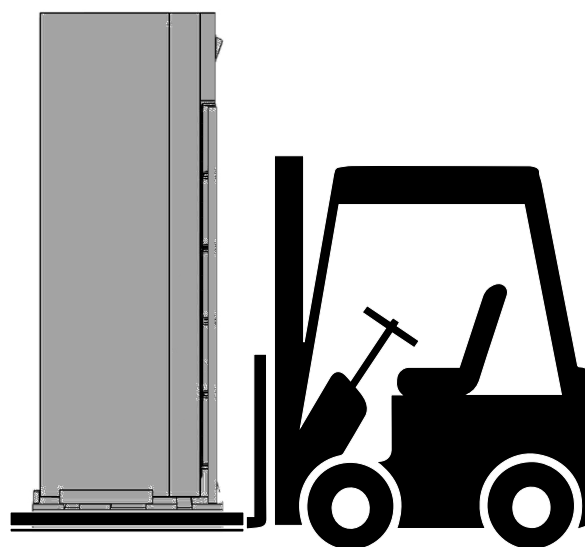

Fig. 14

1. Punti di sollevamento

Tab. I

Modello	Peso (kg)	Peso con imballo (kg)
EPTABRICKS OUTDOOR BT 5 DOORS	140	150
EPTABRICKS OUTDOOR BT 6 DOORS	140	150
EPTABRICKS OUTDOOR TN-AMBIENT 6 DOORS	250	263
EPTABRICKS OUTDOOR TN-AMBIENT 8 DOORS	250	263
EPTABRICKS OUTDOOR TN-AMBIENT 10 DOORS	250	263
EPTABRICKS OUTDOOR DRY 6 DOORS	135	145
EPTABRICKS OUTDOOR DRY 8 DOORS	135	145
EPTABRICKS OUTDOOR DRY 10 DOORS	135	145
EPTABRICKS OUTDOOR MASTER	90	100

Modello - Modèle - Model Modell - Modelo - Modelo	EPTABRICKS 2.0 OUTDOOR	 Epta
Fabbricante - Constructeur - Manufacturer Hersteller - Fabricante - Fabricante	Epta Spa - Via Mecenate, 86 - 20138 Milano (MI) ITALIA Tel. 02/55403211 Telefax 02/55401023	11/27

5. CONDIZIONI AMBIENTALI

IT

FR

EN

DE

ES

PT

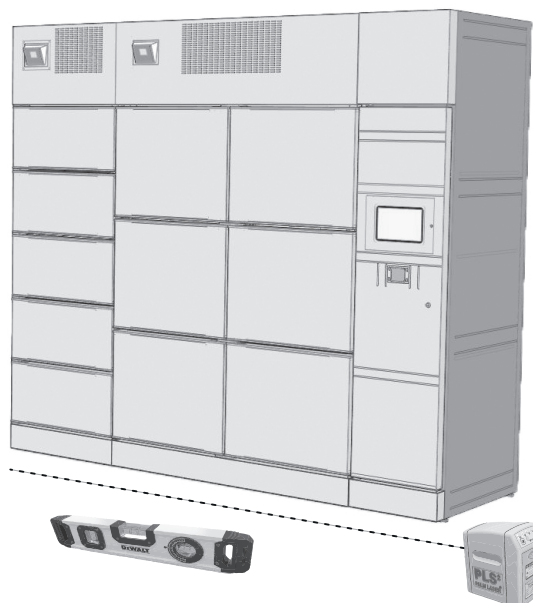

Fig. 15

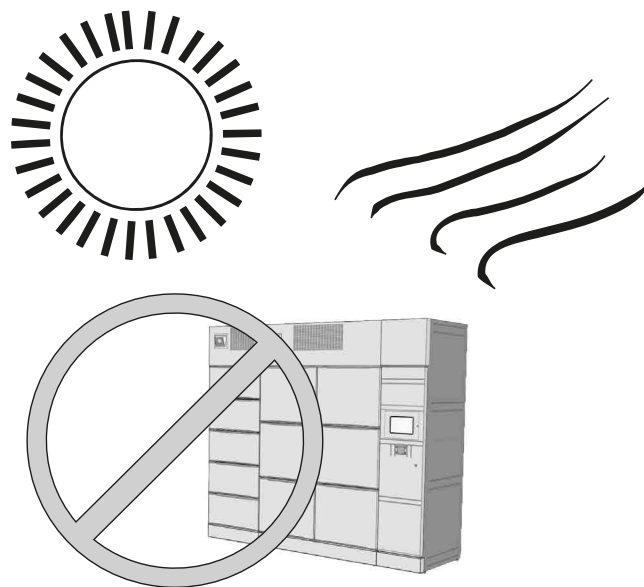

Fig. 17

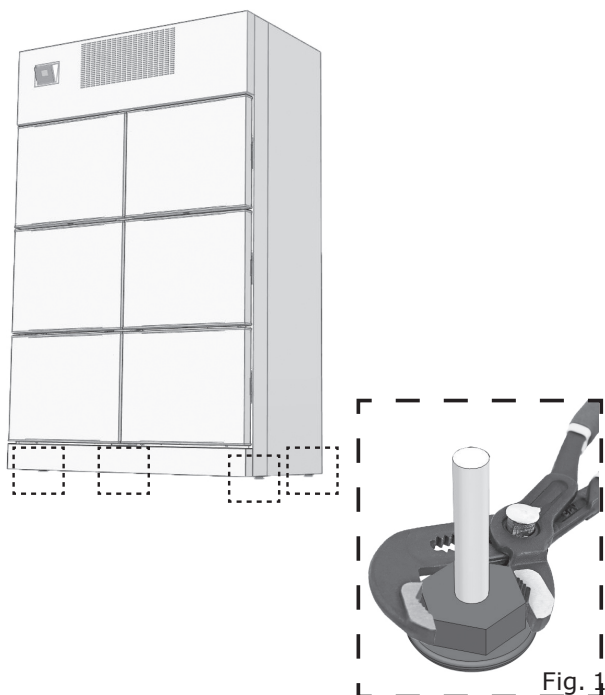

Fig. 16

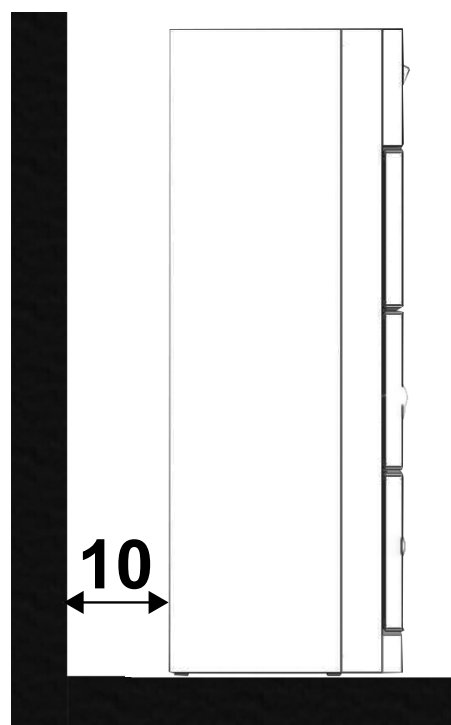

Fig. 18

Modello - Modèle - Model Modell - Modelo - Modelo	EPTABRICKS 2.0 OUTDOOR	 Epta
Fabbricante - Constructeur - Manufacturer Hersteller - Fabricante - Fabricante	Epta Spa - Via Mecenate, 86 - 20138 Milano (MI) ITALIA Tel. 02/55403211 Telefax 02/55401023	12/27

User manual

- IT
- FR
- EN
- DE
- ES
- PT

6. CONDIZIONI AMBIENTALI

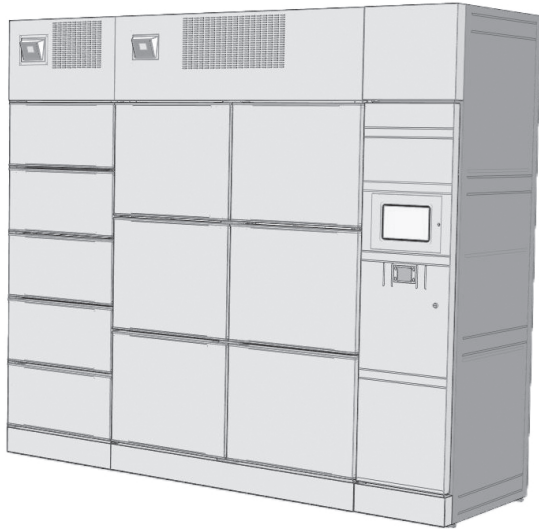

Fig. 19

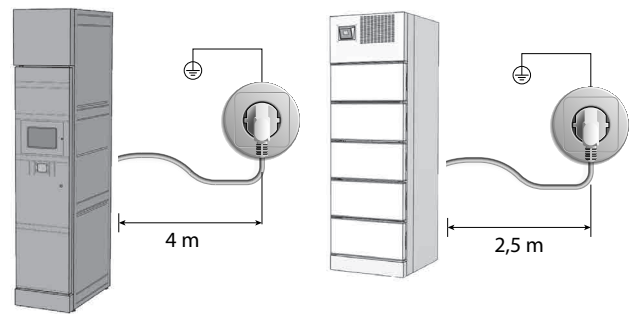

Fig. 20

Tab. II

Caratteristiche ambiente	
Tipo	Valore Massimo
Temperatura	35°C
Umidità relativa	75 %

Modello - Modèle - Model Modell - Modelo - Modelo	EPTABRICKS 2.0 OUTDOOR	
Fabbricante - Constructeur - Manufacturer Hersteller - Fabricante - Fabricante	Epta Spa - Via Mecenate, 86 - 20138 Milano (MI) ITALIA Tel. 02/55403211 Telefax 02/55401023	13/27

7. CARATTERISTICHE TECNICHE

 <small>EPTA S.p.A. Via Mecenate, 86 20138 Milano - Italy</small>		12	
1		2	
3		4	
5		6	
7		8	
9		10	
11		12	
13		14	
15		16	
17		18	
19		20	
21		22	
23		24	
25		CE	

Fig. 21

- | | |
|-----------------------------------|------------------------------|
| 1. Origine del prodotto | 14. Data di produzione |
| 2. Prodotto in "Paese di origine" | 15. Hat Code |
| 3. Tensione nominale | 16. Modello |
| 4. Potenza nominale | 17. Tipo di refrigerante 1 |
| 5. Frequenza nominale | 18. Massa refrigerante 1 |
| 6. Corrente Nominale | 19. Tipo di refrigerante 2 |
| 7. Potenza di sbrinamento | 20. Massa refrigerante 2 |
| 8. Corrente di sbrinamento | 21. Classe climatica |
| 9. Sistema di riscaldamento | 22. Isolamento gas |
| 10. Sistema di illuminazione | 23. Indice di protezione |
| 11. Manuale dell'operatore | 24. Marchi di certificazione |
| 12. Codice a barre | 25. Marchio RAEE |
| 13. Numero di serie | |



Attenzione: contiene gas refrigerante infiammabile.

Tab. III

Quantità di refrigerante R290 (g)	
Modello	Quantità (g)
EPTABRICKS OUTDOOR BT	-
EPTABRICKS OUTDOOR TN	-
EPTABRICKS OUTDOOR AMBIENT	-

Modello - Modèle - Model Modell - Modelo - Modelo	EPTABRICKS 2.0 OUTDOOR	 Epta
Fabbricante - Constructeur - Manufacturer Hersteller - Fabricante - Fabricante	Epta Spa - Via Mecenate, 86 - 20138 Milano (MI) ITALIA Tel. 02/55403211 Telefax 02/55401023	14/27

User manual

IT
FR
EN
DE
ES
PT

8. USO DEL BANCO

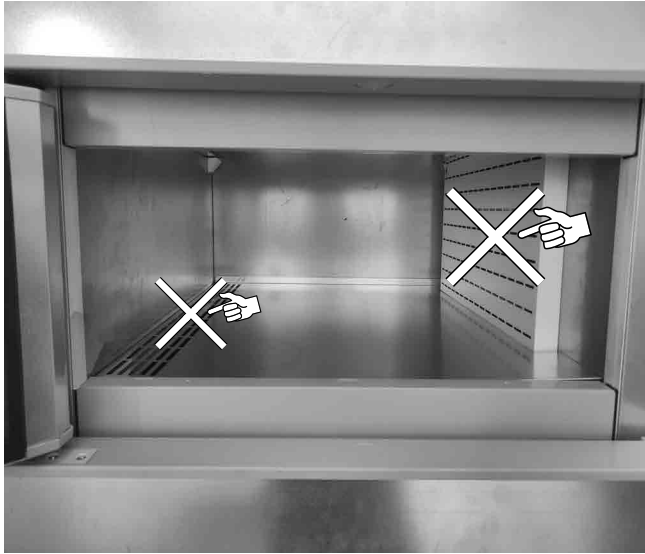

Fig. 22

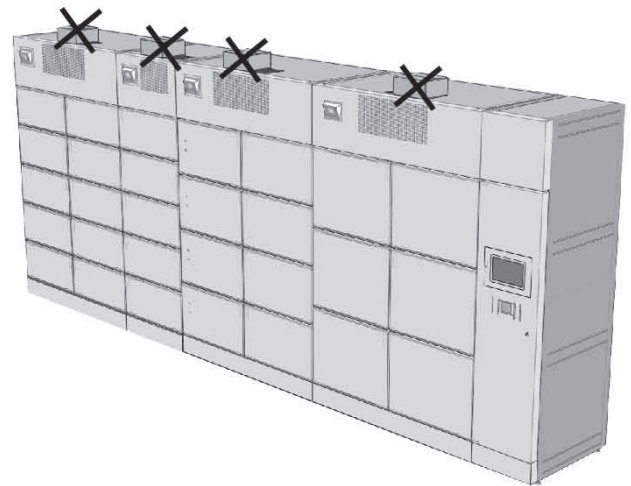



Fig. 24

 Non coprire

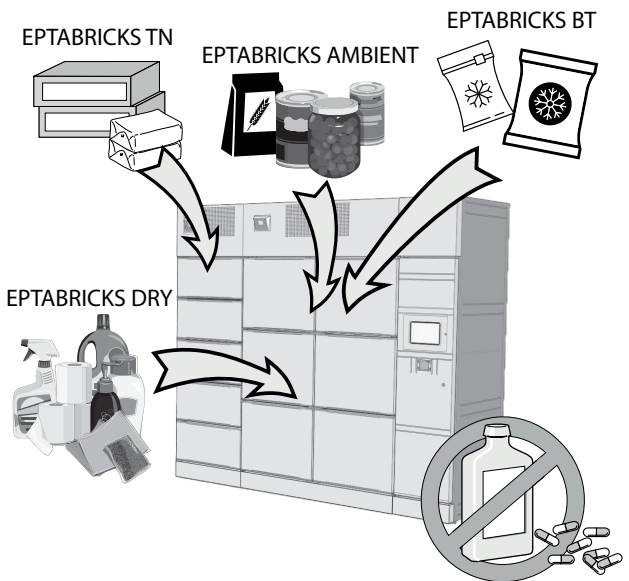

Fig. 23

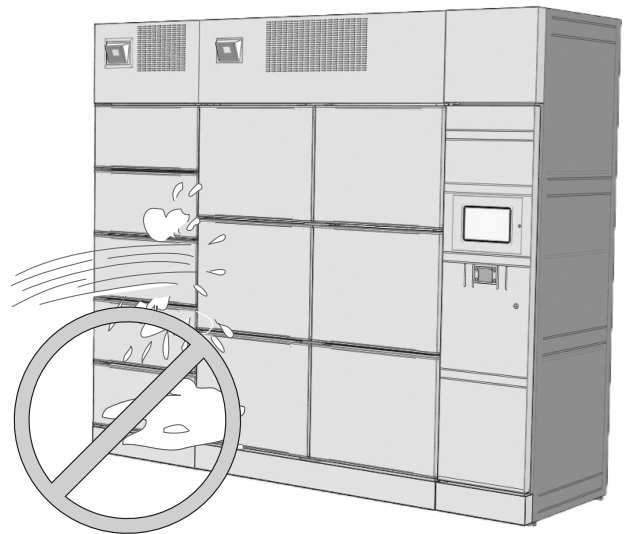

Fig. 25

Modello - Modèle - Model Modell - Modelo - Modelo	EPTABRICKS 2.0 OUTDOOR	
Fabbricante - Constructeur - Manufacturer Hersteller - Fabricante - Fabricante	Epta Spa - Via Mecenate, 86 - 20138 Milano (MI) ITALIA Tel. 02/55403211 Telefax 02/55401023	15/27

- IT
- FR
- EN
- DE
- ES
- PT

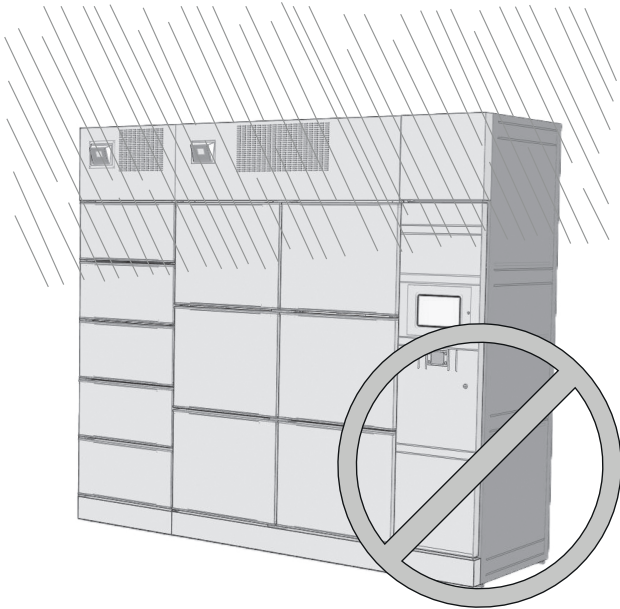

Fig. 26

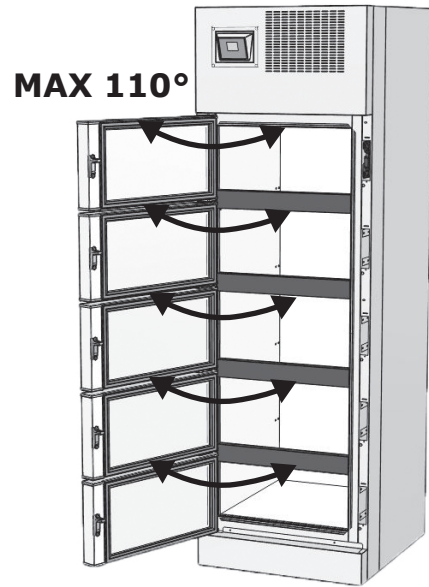

Fig. 28

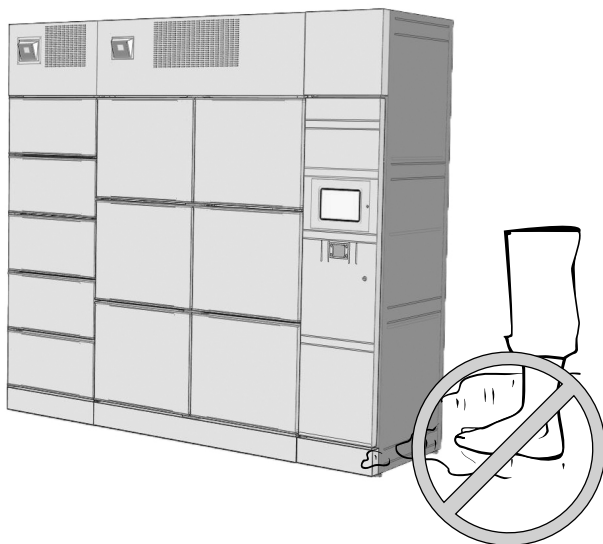

Fig. 27

Modello - Modèle - Model Modell - Modelo - Modelo	EPTABRICKS 2.0 OUTDOOR	 Epta
Fabbricante - Constructeur - Manufacturer Hersteller - Fabricante - Fabricante	Epta Spa - Via Mecenate, 86 - 20138 Milano (MI) ITALIA Tel. 02/55403211 Telefax 02/55401023	16/27

IT
FR
EN
DE
ES
PT

9. MANUTENZIONE ORDINARIA

9.1 Pulizia del banco

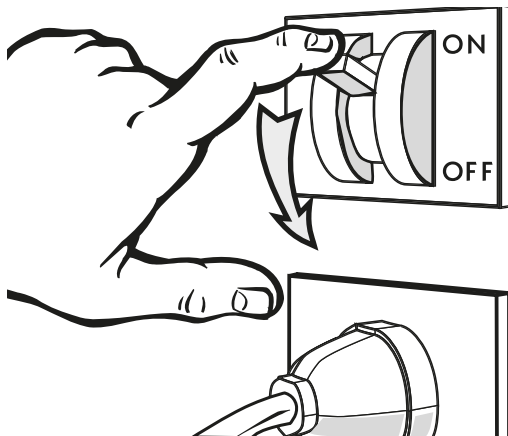

Fig. 29

9.2 Pulizia vaschetta raccolta acqua

- Svitare e rimuovere la copertura inferiore e la copertura vaschetta.



Fig. 31

- Estrarre e pulire la vaschetta.



Fig. 30

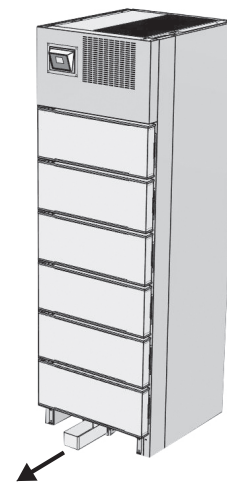

Fig. 32



Pulire in funzione dell'uso e della necessità ed in particolari condizioni ambientali (es. alta umidità, bassa temperatura ambiente, presenza di polveri ecc.) onde evitare, la non corretta e completa evaporazione dell'acqua e/o la presenza di sgradevoli odori.

Modello - Modèle - Model Modell - Modelo - Modelo	EPTABRICKS 2.0 OUTDOOR	
Fabbricante - Constructeur - Manufacturer Hersteller - Fabricante - Fabricante	Epta Spa - Via Mecenate, 86 - 20138 Milano (MI) ITALIA Tel. 02/55403211 Telefax 02/55401023	17/27

10. INDICAZIONI UTENTE

10.1 Descrizione del banco

La linea EPTABRICKS 2.0 OUTDOOR TN è adatta alla conservazione e la vendita di derrate alimentari fresche, preconfezionate, bibite e latticini.

La linea EPTABRICKS 2.0 OUTDOOR BT è adatta alla conservazione e la vendita di prodotti congelati.

La linea EPTABRICKS 2.0 OUTDOOR AMBIENT è adatta alla conservazione e la vendita di prodotti che non richiedono refrigerazione a lunga conservazione.

La linea EPTABRICKS 2.0 OUTDOOR DRY è adatta alla conservazione e la vendita di prodotti NO FOOD.

CLASSE DI TEMPERATURA EPTABRICKS 2.0 OUTDOOR TN (secondo EN-ISO 23953-2): 7M2.
CLASSE DI TEMPERATURA EPTABRICKS 2.0 OUTDOOR BT (secondo EN-ISO 23953-2): 7L1.
CLASSE DI TEMPERATURA EPTABRICKS 2.0 OUTDOOR AMBIENT (secondo EN-ISO 23953-2): 7S.

Durante le fasi di trasporto e movimentazione, ricezione e immagazzinamento, installazione, caricamento, uso, pulizia e manutenzione, smantellamento, prestare attenzione al rischio di ribaltamento del banco ("Fig. 33").

Le caratteristiche generali e le dimensioni sono illustrate nelle figure e nelle sezioni contenute in "Descrizione generale" (a pag. "7").

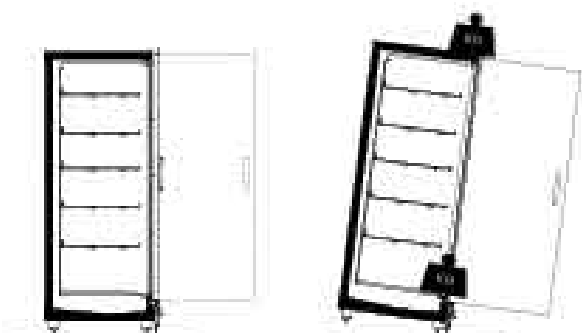

Fig. 33

10.2 Trasporto e movimentazione

Il banco è contenuto in uno specifico imballo provvisto di pedana per la movimentazione con carrelli a forca.

Per il trasporto e la movimentazione del banco utilizzare:

- Esclusivamente una pedana apposita o equivalente
- Un carrello elevatore a mano o elettrico adatto al sollevamento del banco, con caratteristiche idonee nel rispetto delle Norme vigenti

I pesi del banco (vuoto e con imballo) e le dimensioni dell'imballo sono riportati in "Trasporto del banco" (tabella "Tab. I" e figure a pag. "11").

Le operazioni di movimentazione devono essere svolte da personale qualificato, in grado di valutare pesi, punti di sollevamento e mezzi più idonei sia per sicurezza che per portata.

10.3 Ricezione ed immagazzinamento

Controllare le condizioni dell'imballo prima di prendere in consegna il banco dal trasportatore. Se ci sono danni evidenti nell'imballo:

- Rimuovere l'imballo del banco in presenza del trasportatore.
- Firmare con riserva il documento di consegna

Il costruttore non risponde di eventuali danni dovuti al trasporto o ad un errato stoccaggio del banco.

Il banco deve essere conservato in un luogo riparato da sole ed intemperie, con una temperatura compresa tra -25°C e +55°C e un'umidità relativa dell'aria compresa tra 30% e 95%.

Modello - Modèle - Model Modell - Modelo - Modelo	EPTABRICKS 2.0 OUTDOOR	 Epta
Fabbricante - Constructeur - Manufacturer Hersteller - Fabricante - Fabricante	Epta Spa - Via Mecenate, 86 - 20138 Milano (MI) ITALIA Tel. 02/55403211 Telefax 02/55401023	18/27

10.4 Installazione e condizioni ambientali

Il banco non è progettato per un'installazione da esterno.

Per un corretto funzionamento del banco, verificare che sia posizionato:

- Su un pavimento livellato ("Fig. 15").
- L'apparecchio è dotato di piedi regolabili, per fermare e posizionare l'apparecchio ("Fig. 16"). È assolutamente necessario dopo il posizionamento stabilizzare l'apparecchio al pavimento, assicurandosi che sia perfettamente in piano.
- E' molto importante che il gruppo motocompressore posto nella parte superiore della colonna sia sempre coperto da una pensilina protettiva. Non lasciarlo esposto direttamente alla radiazione diretta del sole, alla pioggia e alle intemperie. ("Fig. 17").
- E' fondamentale rispettare le distanze indicate in "Fig. 18" (cm) per una corretta installazione dell'apparecchio.

Assicurare lo spazio necessario all'uso del banco da parte della clientela.

Le condizioni dell'ambiente in cui porre il banco sono riportate in "Condizioni ambientali".

10.5 Collegamento elettrico



Se il banco refrigerato è stato fortemente inclinato a causa del posizionamento o dei montaggio accessori, attendere minimo 3 ore prima della messa in funzione in modo da permettere all'olio lubrificante di raccogliersi nel compressore. Se questa prescrizione non viene osservata, la macchina frigorifera a compressione può essere danneggiata irreparabilmente.



LA LINEA DI ALIMENTAZIONE ELETTRICA A CUI SARA' ALLACCIATO IL FRIGORIFERO DEVE ESSERE PROTETTA DA INTERRUTTORE DIFFERENZIALE AD ALTA SENSIBILITA' (In=16 A, Id = 30 mA) E COLLEGATO ALL' IMPIANTO GENERALE DI TERRA. La messa a terra è necessaria ed obbligatoria per un corretto funzionamento dell'apparecchio.

A monte del banco deve essere installato un interruttore sezionatore omnipolare. Questo deve avere:

- Distanza minima dei contatti di 3 mm
- Potere di interruzione adeguato

Il cavo deve essere ben teso, in posizione riparata da eventuali urti, non deve essere in prossimità di liquidi o acqua e a fonti di calore, non deve essere danneggiato. In caso di rottura del cavo di alimentazione del banco, esso deve essere sostituito dal costruttore oppure da un ente da esso preposto.

L'interruttore sezionatore deve essere posto in una posizione tale da renderlo facilmente azionabile in situazioni di emergenza (distanza massima di 3 m).

Prima di collegare il banco, accertarsi che la tensione di alimentazione corrisponda ai dati di targa del banco. Per garantire un funzionamento regolare, la variazione massima di tensione deve essere compresa tra +/- 6% del valore nominale.

10.6 Caratteristiche tecniche

La targa matricolare riporta i dati tecnici caratteristici del banco. La sua posizione e la tipologia di dati sono riportati in "Caratteristiche tecniche" ("Fig. 21").

Schemi elettrici, distinte di taratura degli strumenti di controllo, istruzioni di Installazione e copia della Dichiarazione di Conformità sono disponibili sul sito <https://documents.eptarefrigeration.com>.

Il livello di pressione sonora generato dal funzionamento del banco è inferiore a 70 dB(A). Il banco non provoca vibrazioni dannose.

Modello - Modèle - Model Modell - Modelo - Modelo	EPTABRICKS 2.0 OUTDOOR	
Fabbricante - Constructeur - Manufacturer Hersteller - Fabricante - Fabricante	Epta Spa - Via Mecenate, 86 - 20138 Milano (MI) ITALIA Tel. 02/55403211 Telefax 02/55401023	19/27

10.7 Caricamento del prodotto

Dare tensione al banco per dare inizio al suo ciclo di raffreddamento, agendo sull'interruttore sezionatore generale a parete. Dopo circa 2 ore è possibile caricare il banco.

Il banco è atto a conservare la temperatura della merce e non ad abatterla; le derrate, quindi, devono essere introdotte al suo interno solo se già raffreddate alle loro rispettive temperature di conservazione. Prodotti che abbiano subito un riscaldamento non devono mai essere introdotti nel banco.

Nel caricamento della merce, fare in modo che:

- Il carico sia omogeneo per dimensione e qualità della merce stessa
- La merce non ostruisca il corretto flusso d'aria refrigerata ("Fig. 22")
- Per una buona conservazione del prodotto, all'interno dello sportello mantenere una distanza di 10 mm dalla parte superiore.



MASSIMO ANGOLO DI APERTURA SPORTELLO: 110°. Per un corretto funzionamento e per evitare eventuali cedimenti e/o problematiche, occorre non forzare l'apertura degli sportelli per un angolo superiore ai 110°.

Carico massimo ammissibile uniformemente distribuito: 32 Kg .

10.8 Accesso

Informazioni per l'accesso

Il modello EptaBricks ha un software installato da EPTA su ogni punto di raccolta.

In questo manuale viene descritto l'accesso al software tramite:

- Profilo cliente
- Profilo addetto consegne

Ogni profilo ha diritti, necessità e quindi una visione diversa del menu.

Attenzione! La serratura sportello è dotata di un riscontro magnetico, in caso di sportello aperto verrà segnalata l'apertura con un allarme.

Profilo cliente - Ritiro prodotti

La colonna MASTER consente il ritiro degli ordini, sia mediante la scansione / immissione del numero di ordine, sia tramite la scansione / immissione della carta fedeltà.

Nel caso della cartà fedeltà, se il cliente ha più ordini negli sportelli, apparirà una schermata specifica con l'elenco degli ordini che possono essere raccolti.

Gli sportelli si aprono uno alla volta; per aprire lo sportello successivo bisogna chiudere lo sportello precedente.

Al termine del ritiro il cliente ha la possibilità di:

- Finire il ritiro, quindi ritornare alla schermata iniziale.
- Aprire nuovamente gli sportelli (nel caso il cliente abbia il dubbio di aver dimenticato qualche articolo).

Nel caso si verificasse un problema durante il ripristino, verrà visualizzato un messaggio appropriato al cliente. Questa schermata viene personalizzata in base al punto vendita.

- Accedere al ritiro prodotto premendo il tasto bianco centrale.



**#EPTABricks
24/7**

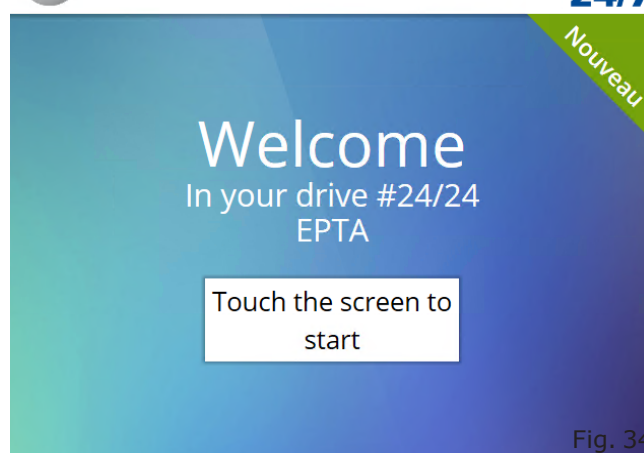

Fig. 34

Modello - Modèle - Model Modell - Modelo - Modelo	EPTABRICKS 2.0 OUTDOOR	
Fabbricante - Constructeur - Manufacturer Hersteller - Fabricante - Fabricante	Epta Spa - Via Mecenate, 86 - 20138 Milano (MI) ITALIA Tel. 02/55403211 Telefax 02/55401023	20/27

User manual

- IT
- FR
- EN
- DE
- ES
- PT

- Inserire il numero di ordine sulla destra dello schermo oppure scansionare il QR code.

- Selezionare se il ritiro della merce è terminato o se si desidera riaprire gli sportelli.

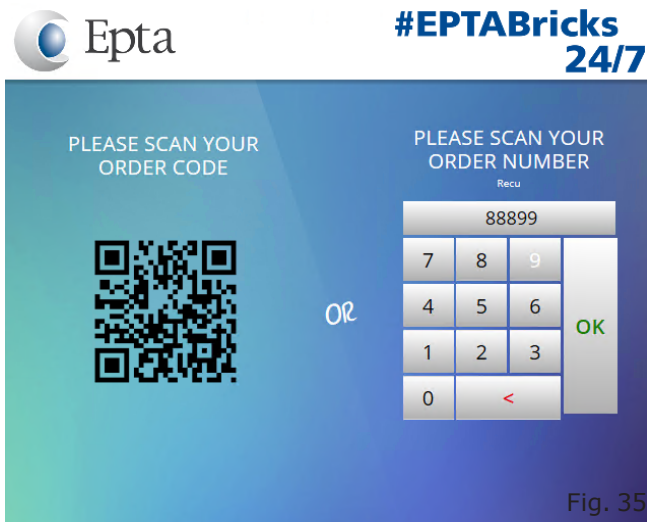

Fig. 35



Fig. 37

- Ritirare la merce dallo sportello indicato sul display della colonna Master. Una volta ritirata la merce si prega di chiudere lo sportello.

Profilo addetto consegne - Caricamento prodotti

La creazione, l'attivazione e la disattivazione degli accounts consegna avvengono direttamente nel terminale di raccolta. Ogni addetto alle consegne dispone di un numero indentificatore univoco con il quale può eseguire scansione oppure accedere al terminale. L'addetto alla consegna ha la possibilità di visualizzare quanti sportelli sono liberi, la presenza di allarmi e scegliere la modalità consegna:

- AutoAllocation: La prima porta si apre automaticamente e alla chiusura si aprirà la porta successiva.
- NoAutoAllocation: L'addetto alla consegna sceglie quale porta aprire cliccando su di essa.

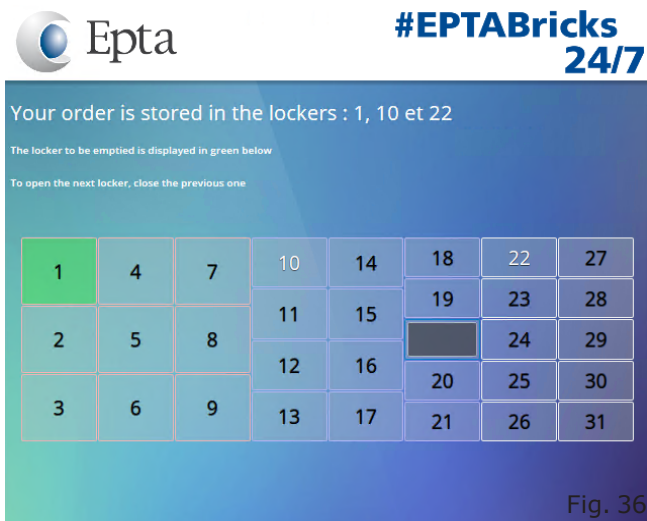

Fig. 36

Modello - Modèle - Model Modell - Modelo - Modelo	EPTABRICKS 2.0 OUTDOOR	 Epta
Fabbricante - Constructeur - Manufacturer Hersteller - Fabricante - Fabricante	Epta Spa - Via Mecenate, 86 - 20138 Milano (MI) ITALIA Tel. 02/55403211 Telefax 02/55401023	21 / 27

- Accedere al caricamento prodotto premendo il tasto bianco centrale.



Fig. 38

- Visualizzare gli sportelli liberi, selezionare la modalità di consegna e premere il tasto "Caricamento".

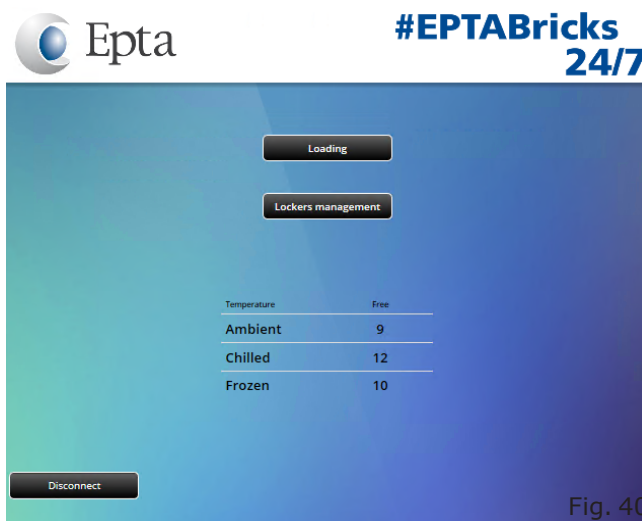

Fig. 40

- Scansionare/Inserire il numero identificativo dell'addetto al caricamento.

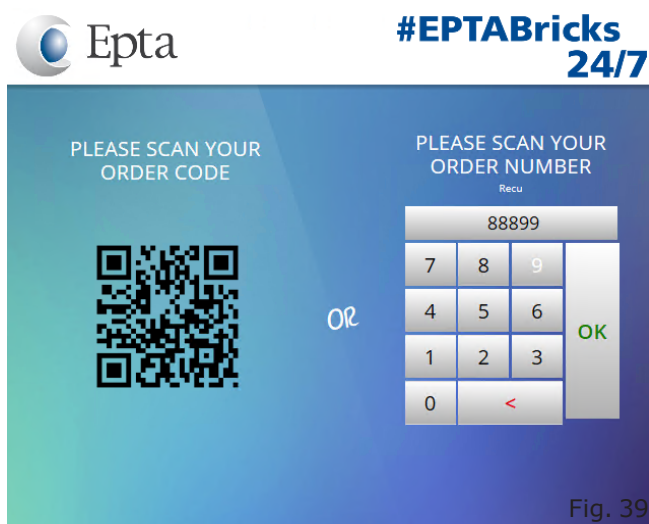

Fig. 39

- Inserire il numero di ordine e premere OK.



Fig. 41

Modello - Modèle - Model Modell - Modelo - Modelo	EPTABRICKS 2.0 OUTDOOR	
Fabbricante - Constructeur - Manufacturer Hersteller - Fabricante - Fabricante	Epta Spa - Via Mecenate, 86 - 20138 Milano (MI) ITALIA Tel. 02/55403211 Telefax 02/55401023	22/27

User manual

IT
FR
EN
DE
ES
PT

- Si attiverà e aprirà lo sportello da caricare. Non appena caricato lo sportello di prega di chiuderlo.

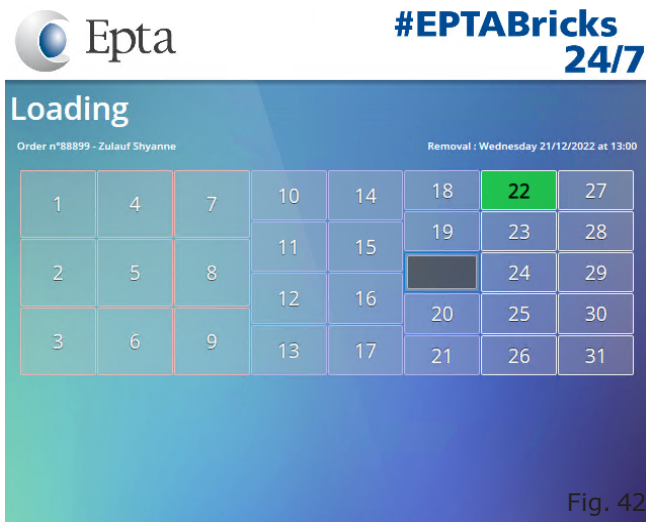

- Conclusi gli sportelli assegnati all'ordine, si possono aggiungere manualmente ulteriori sportelli premendo il tasto in basso a destra.



- Se l'ordine richiede il caricamento di più sportelli (causa quantità o esigenze di diverse temperature), alla chiusura dello sportello si aprirà quello successivo.

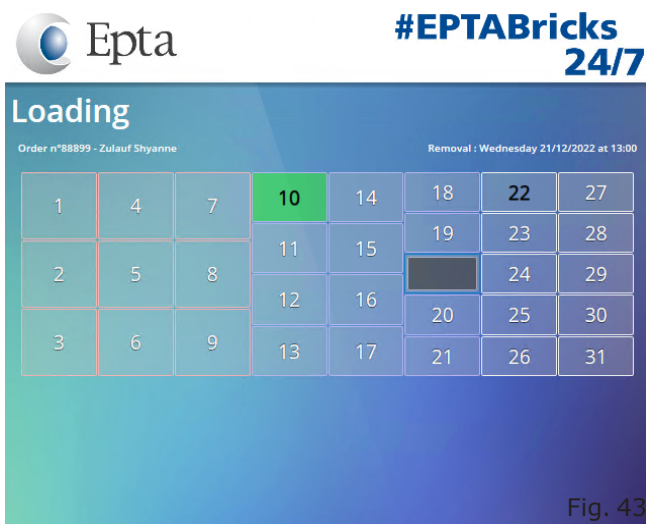

- Selezionare la tipologia di sportello che si vuole aggiungere.



Modello - Modèle - Model Modell - Modelo - Modelo	EPTABRICKS 2.0 OUTDOOR	
Fabbricante - Constructeur - Manufacturer Hersteller - Fabricante - Fabricante	Epta Spa - Via Mecenate, 86 - 20138 Milano (MI) ITALIA Tel. 02/55403211 Telefax 02/55401023	23/27

- Verrà attivato e aperto lo sportello aggiuntivo richiesto. Non appena caricato il prodotto si prega di chiudere lo sportello.

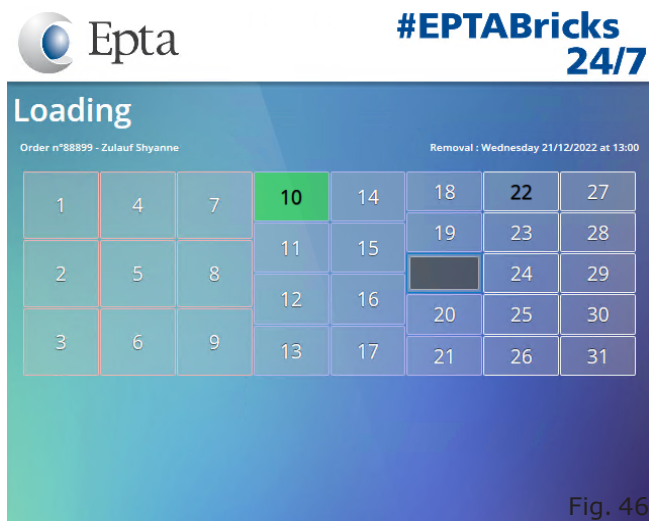

Fig. 46

- Se si desidera aggiungere un'ulteriore sportello, premere nuovamente il testo in basso a destra. Se invece il prodotto è stato tutto caricato, premere il testo in basso a sinistra.

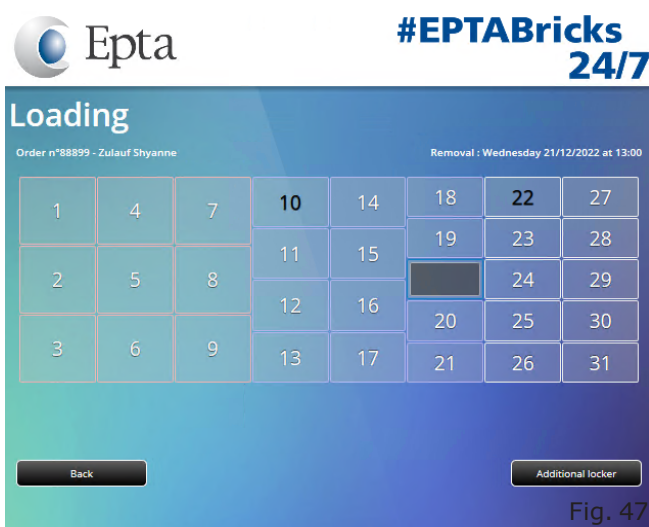

Fig. 47

10.9 Pulizia e manutenzione ordinaria

Si consiglia una buona visibilità nella zona di intervento, eventualmente servendosi di una ulteriore fonte di illuminazione.

Pulizia del banco

Utilizzare esclusivamente acqua a temperatura massima di 65°C e sapone o detergente neutro di uso domestico diluito in acqua.

Non utilizzare assolutamente:

- Spugne abrasive
- Prodotti infiammabili o abrasivi come alcool, acetone o solventi
- Detergenti che contengono tensioattivi non ionici, limone o aceto (acido acetico)



Non lavare o pulire con acqua o liquidi la parte superiore del banco.

Pulire **UNA VOLTA A SETTIMANA** tutte le parti esterne del banco: pulire delicatamente il mobile esterno usare un panno morbido imbevuto di soluzione di acqua e detersivo neutro.

SCHERMO TOUCH SCREEN: non usare mai solventi di alcun tipo, non versare mai acqua direttamente sullo schermo. Inumidire leggermente un panno in cotone e passarlo sullo schermo per rimuovere lo sporco o il materiale estremo. Asciugare bene lo schermo e passare con un panno in microfibra.

Pulire **UNA VOLTA AL MESE** tutte le parti interne del banco, seguendo le istruzioni sotto riportate:

- Togliere la tensione elettrica al banco tramite l'interruttore sezionatore generale a parete ("Fig. 29").
- Svuotare il banco, stoccando la merce in celle o refrigeratori atti a mantenerne la temperatura di conservazione.
- Attendere che l'interno del banco abbia raggiunto la temperatura ambiente e procedere alla pulizia
- Dopo aver controllato attentamente che l'interno del banco sia completamente asciutto, rimettere in funzione l'apparecchio ridando tensione al banco.
- Dopo circa un paio d'ore caricare nuovamente la merce.

Modello - Modèle - Model Modell - Modelo - Modelo	EPTABRICKS 2.0 OUTDOOR	 Epta
Fabbricante - Constructeur - Manufacturer Hersteller - Fabricante - Fabricante	Epta Spa - Via Mecenate, 86 - 20138 Milano (MI) ITALIA Tel. 02/55403211 Telefax 02/55401023	24/27

User manual

IT

Quando si mette fuori servizio il banco, scollegare l'alimentazione e seguire i passaggi precedenti, lasciando gli sportelli aperti (se presenti) per evitare cattivi odori.

FR

EN

DE

ES

PT

Procedere **OGNI TRE MESI** allo sbrinamento del banco per permettere lo scioglimento del ghiaccio che si può essere formato sulle alette dell'evaporatore impedendone il corretto funzionamento. La durata e il numero di sbrinamenti sono regolati direttamente in fabbrica. Eventuali regolazioni sono riservate esclusivamente al servizio tecnico di assistenza. L'acqua di sbrinamento viene raccolta da un apposito scarico e convogliata in una bacinella di dissipazione posta nella base del banco. Verificare periodicamente che l'acqua di sbrinamento defluisca normalmente.

Pulizia vaschetta evaporazione acqua

Pulire **IN FUNZIONE DELL'USO** e della necessità ed in particolari condizioni ambientali (es. alta umidità, bassa temperatura ambiente, presenza di polveri ecc.) onde evitare, la non corretta e completa evaporazione dell'acqua e/o la presenza di sgradevoli odori.

10.10 Situazioni di emergenza

Il banco non parte o si arresta:

- Verificare che non vi sia una situazione di blackout elettrico.
- Controllare che l'interruttore generale a parete sia acceso.
- Controllare che la spina del banco sia inserita nella presa di corrente.

Se l'interruzione elettrica non dipende da questi motivi, rivolgersi al più vicino centro di assistenza autorizzato e procedere allo svuotamento completo ed allo stoccaggio immediato del prodotto in celle o refrigeratori atti a mantenerne la temperatura di conservazione.

Il banco non raffredda a sufficienza:

- Verificare che il condensatore sia pulito e che sia in grado di svolgere la sua funzione di scambio di calore; procedere ad un'accurata pulizia se le alette sono ostruite.
- Controllare che il caricamento del banco sia corretto.
- Sbrinare il banco per poi riprendere il funzionamento normale, se questa operazione non viene effettuata da più di tre mesi.
- Controllare che il banco non sia vicino a fonti di calore o correnti d'aria.
- Verificare le condizioni ambientali riportate in "Condizioni ambientali" ("Tab. II").
- Controllare, tramite una livella, la planarità del banco.
- Controllare la perfetta chiusura della porta.

Se il mancato raffreddamento persiste, rivolgersi al più vicino centro di assistenza autorizzato.

Modello - Modèle - Model Modell - Modelo - Modelo	EPTABRICKS 2.0 OUTDOOR	 Epta
Fabbricante - Constructeur - Manufacturer Hersteller - Fabricante - Fabricante	Epta Spa - Via Mecenate, 86 - 20138 Milano (MI) ITALIA Tel. 02/55403211 Telefax 02/55401023	25/27

Il banco è rumoroso:

- Controllare che viti e bulloni siano perfettamente chiusi.
- Controllare, tramite una livella, la planarità del banco.

Se l'inconveniente persiste, rivolgersi al più vicino centro di assistenza autorizzato.

10.11 Assistenza tecnica

Qualora si rendesse necessario l'intervento del personale tecnico di assistenza, contattare immediatamente il fornitore presso il quale è stato acquistato il banco.

Qualora vi fosse la necessità di usare pezzi di ricambio fare sempre riferimento al servizio tecnico di assistenza: chiedere ed accertarsi che vengano utilizzati ricambi originali.

10.12 Smantellamento ed eliminazione

AVVERTENZE PER IL CORRETTO SMALTIMENTO DEL PRODOTTO AI SENSI DELLA DIRETTIVA EUROPEA 2012/19/UE

Per motivi inerenti la protezione dell'ambiente, e in conformità a quanto disposto dalla Direttiva 2011/65/EC, i mobili per prodotti refrigerati e surgelati devono essere al termine del ciclo di vita smaltiti e riciclati in modo appropriato.

Assicurandosi che ciò venga fatto, l'utente contribuisce a prevenire in modo significativo le potenziali conseguenze per l'ambiente e la salute.

I mobili completi di impianto di refrigerazione e dotati di spina di alimentazione (e quindi pronti all'installazione), sono definiti WEEE: "Waste Electrical and Electronic Equipment (rifiuti di apparecchiature elettriche ed elettroniche)".

- RiConferire i mobili agli appositi centri specializzati al recupero e riciclaggio dei WEEE.
- In alternativa riconsegnare i mobili al rivenditore o al costruttore.
- In tutti i casi la raccolta dei WEEE da sottoporre ad operazioni di trattamento deve essere effettuata adottando criteri che garantiscano la protezione delle apparecchiature dismesse durante il trasporto e durante le operazioni di carico e scarico. Non lasciare gli apparecchi incustoditi neanche per pochi giorni.
- Evitare danneggiamenti al circuito di refrigerazione che contiene fluidi con potenziali effetti dannosi sull'ecosistema e soggetti a particolari prescrizioni.
- Assicurare la chiusura degli sportelli e fissare in modo adeguato le parti mobili.
- Staccare la spina di alimentazione delle apparecchiature fuori uso e tagliare il cavo di alimentazione in modo da renderle inutilizzabili.

Il simbolo riportato sulla targa matricolare del mobile e sulla documentazione di accompagnamento, indica che:

IT

FR

EN

DE

ES

PT

Modello - Modèle - Model Modell - Modelo - Modelo	EPTABRICKS 2.0 OUTDOOR	 Epta
Fabbricante - Constructeur - Manufacturer Hersteller - Fabricante - Fabricante	Epta Spa - Via Mecenate, 86 - 20138 Milano (MI) ITALIA Tel. 02/55403211 Telefax 02/55401023	26/27

IT
FR
EN
DE
ES
PT

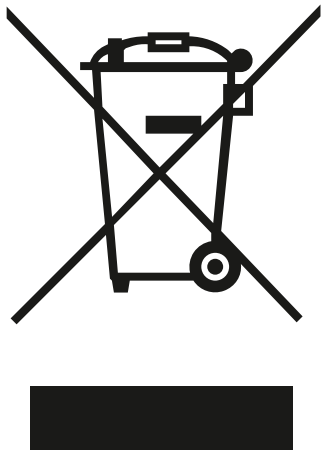

Fig. 48

- il prodotto è stato messo in circolazione dopo la data del 13 agosto 2005;
- il prodotto è soggetto a "raccolta separata", non deve essere trattato come rifiuto domestico e non può essere conferito in discarica.

Per ulteriori informazioni sul trattamento, recupero e riciclaggio di questo prodotto, contattare l'idoneo ufficio locale, il servizio di raccolta dei rifiuti domestici o il rivenditore presso il quale il prodotto è stato acquistato.
SI DICHIARA CHE IL MOBILE E' CONFORME ALLA DIRETTIVA RoHS 2011/65/EC.



L'apparecchio contiene olio, gas refrigerante infiammabile, parti in plastica, parti metalliche e vetro. Attenzione! L'isolamento poliuretano utilizza come espandente CICLOPENTANO, una sostanza senza effetti sull'ambiente, ma infiammabile. Per garantire la massima cura per gli aspetti ambientali all'atto della demolizione si raccomanda di non abbandonare mai l'apparecchio nell'ambiente. Non gettate l'imballo dell'apparecchio nella spazzatura bensì selezionate i vari materiali quali: polistirolo, cartone, sacchi di plastica. La demolizione dell'apparecchio ed il recupero dei materiali componenti deve avvenire nel rispetto delle locali normative vigenti in materia.

In caso di apparecchio fuori uso:

- Togliere la spina di alimentazione.
- Tagliare il cavo di alimentazione e eliminarlo insieme alla spina.
- Non estrarre i componenti nell'interno vasca, in modo da rendere più difficoltoso ai bambini l'entrata nel vano refrigerato dell'apparecchio.
- I bambini hanno divieto di giocare con l'apparecchio dismesso. Pericolo di asfissia!
- L'apparecchio contiene gas infiammabile all'interno del circuito refrigerante che deve essere smaltito in modo appropriato. è necessario evitare di danneggiare le parti del circuito refrigerante, durante lo smaltimento dell'apparecchio.

I componenti del circuito di refrigerazione non devono essere tagliati e/o separati prima che venga scaricato il circuito, con recupero del gas refrigerante da parte di personale qualificato.

Modello - Modèle - Model Modell - Modelo - Modelo	EPTABRICKS 2.0 OUTDOOR	
Fabbricante - Constructeur - Manufacturer Hersteller - Fabricante - Fabricante	Epta Spa - Via Mecenate, 86 - 20138 Milano (MI) ITALIA Tel. 02/55403211 Telefax 02/55401023	27/27

11. AVVERTENZE GENERALI INTEGRATIVE

Istruzioni per la corretta installazione e manutenzione

Le istruzioni di uso e manutenzione si trovano nel Manuale Utente disponibile nel sito: www.eptarefrigeration.com.

Le istruzioni di installazione dedicate al personale esperto sono disponibili:

- Presso la rete di assistenza
- In alcune categorie di prodotto in forma cartacea consegnato insieme al prodotto

Servizi professionali di riparazione

I servizi sono erogati dalla nostra rete di assistenza consultabile nell'area contatti all'indirizzo web www.eptarefrigeration.com.

Parti di ricambio

Le parti di ricambio e le informazioni per la riparazione dell'apparecchio sono disponibili per almeno 8 anni dopo che il prodotto viene dichiarato fuori produzione al seguente indirizzo web: www.epta-service.com/service.

Le credenziali di accesso sono fornite su richiesta da inviare via mail a: servicesupport@eptarefrigeration.com.

Pulizia del condensatore ad aria

Le apparecchiature a gruppo incorporato con condensazione ad aria mantengono la loro efficienza solo se la pulizia del condensatore è eseguita nei modi e nei tempi indicati nel manuale di uso e manutenzione.

Informazione importante sugli sprechi alimentari

Si raccomanda di seguire attentamente le istruzioni di conservazione riportate nelle confezioni dei prodotti e le indicazioni fornite dai produttori di alimenti.

Pertanto, le impostazioni di temperatura devono essere adeguate alle caratteristiche di conservazione dei prodotti alimentari coerentemente con le indicazioni riportate nella nostra documentazione tecnica.

Utilizzi non corretti possono causare un deperimento.

Condizioni ambientali

Il presente apparecchio è destinato a funzionare in ambienti in cui la temperatura e l'umidità rientrano nei limiti previsti nel Manuale di uso e manutenzione.

Istruzioni per il disassemblaggio

Per il disassemblaggio occorre rivolgersi ad operatori professionali.

Il gruppo Epta, da sempre animato da una particolare attenzione per l'ambiente, mette a disposizione degli utenti i manuali di smantellamento e trattamento dei rifiuti dei banchi frigoriferi plug-in, scaricabili di seguito.

- Manuale di smantellamento banchi plug-in aperti:



- Manuale di smantellamento banchi plug-in chiusi:



Altre informazioni

Per ulteriori e più dettagliate informazioni si prega di fare riferimento a www.eptarefrigeration.com ed a EPREL a cui si accede attraverso il QR code qui o nell'etichetta energetica del prodotto.



Modello - Modèle - Model Modell - Modelo - Modelo	EPTABRICKS 2.0 OUTDOOR	
Fabbricante - Constructeur - Manufacturer Hersteller - Fabricante - Fabricante	Epta Spa - Via Mecenate, 86 - 20138 Milano (MI) ITALIA Tel. 02/55403211 Telefax 02/55401023	1/27

TABLE DES MATIÈRES

1. Introduction	2	IT
2. Avertissements de sécurité	3	FR
2.1 Avertissements pour les appareils utilisant le R290 (propane) et le R600a (isobutane)	3	
2.2 Avertissements généraux	3	EN
2.3 Avertissements pour l'entretien du meuble réfrigéré	4	DE
2.4 Avertissements électriques	5	ES
2.5 Interdictions	5	PT
3. Description générale	6	
3.1 Vues en coupe	7	
4. Transport du meuble réfrigéré	10	
5. Conditions ambiantes	11	
6. Conditions ambiantes	12	
7. Caractéristiques techniques	13	
8. Utilisation du meuble réfrigéré	14	
9. Entretien ordinaire	16	
9.1 Nettoyage du meuble réfrigéré	16	
9.2 Nettoyage bac de collecte eau	16	
10. Indications utilisateur	17	
10.1 Descriptions du meuble réfrigéré	17	
10.2 Transport et déplacement	17	
10.3 Réception et stockage	17	
10.4 Installation et conditions ambiantes	18	
10.5 Connexion électrique	18	
10.6 Caractéristiques techniques	18	
10.7 Chargement du produit	19	
10.8 Accès	19	
10.9 Nettoyage et entretien ordinaire	23	
10.10 Situations d'urgence	24	
10.11 Service après-vente	25	
10.12 Démantèlement et élimination	25	
11. Avertissements généraux supplémentaires	27	

SYMBOLIQUE UTILISÉE

Symbole d'interdiction: interdiction d'effectuer certaines opérations.



Symbole d'attention: normes anti-accident pour l'opérateur.



Symbole d'avertissement : risque d'endommager la porte frigorifique et/ou ses composants.



Symbole de remarque: fourniture d'informations utiles.

Modello - Modèle - Model Modell - Modelo - Modelo	EPTABRICKS 2.0 OUTDOOR	
Fabbricante - Constructeur - Manufacturer Hersteller - Fabricante - Fabricante	Epta Spa - Via Mecenate, 86 - 20138 Milano (MI) ITALIA Tel. 02/55403211 Telefax 02/55401023	2/27

1. INTRODUCTION

Veillez lire attentivement ce manuel et le conserver avec le meuble réfrigéré.

Le constructeur décline toute responsabilité pour tout préjudice causé aux personnes ou aux biens, dû au non-respect des consignes indiquées dans ce manuel.



Fig. 1

Ce manuel fournit les informations considérées comme nécessaires pour une utilisation correcte et un bon fonctionnement du meuble réfrigéré.

Il contient les descriptions et les informations suivantes:

- une description fonctionnelle du meuble réfrigéré et de chacune de ses parties
- des informations concernant la sécurité du meuble réfrigéré et les règles anti-accident auxquelles se conformer
- une utilisation correcte du meuble réfrigéré
- un bon entretien ordinaire et programmé, y compris les opérations de nettoyage

Pour une installation correcte du meuble réfrigéré, veuillez faire référence aux documents suivants:

- Instructions de référence rapides

Ce manuel s'adresse aux professionnels suivants:

- **OPÉRATEUR QUALIFIÉ** personne qualifiée, instruite pour effectuer le fonctionnement, le réglage, le nettoyage et l'entretien ordinaire du meuble réfrigéré
- **TECHNICIEN SPÉCIALISÉ** formé et autorisé par l'organisme indiqué dans le contrat (constructeur/concessionnaire/distributeur) à effectuer: l'installation, l'entretien exceptionnel, la réparation, le remplacement et la révision du meuble réfrigéré

Ces instructions sont aussi disponibles sur : www.eptarefrigeration.com.

En ce qui concerne les réglementations et les certifications du meuble réfrigéré, veuillez faire référence à la déclaration de conformité.

Conservez toujours le livret d'instructions et en cas de vente.

Modello - Modèle - Model Modell - Modelo - Modelo	EPTABRICKS 2.0 OUTDOOR	
Fabbricante - Constructeur - Manufacturer Hersteller - Fabricante - Fabricante	Epta Spa - Via Mecenate, 86 - 20138 Milano (MI) ITALIA Tel. 02/55403211 Telefax 02/55401023	3/27

2. AVERTISSEMENTS DE SÉCURITÉ

2.1 Avertissements pour les appareils utilisant le R290 (propane) et le R600a (isobutane)



L'isobutane et le propane sont des gaz naturels sans effet sur l'environnement mais inflammables. Il est donc indispensable de s'assurer que tous les tuyaux du circuit de refroidissement ne sont pas endommagés, avant de brancher le banc au réseau d'alimentation. La pièce où le banc est installé doit disposer d'un volume minimum de 1m³ par 8g de réfrigérant. La quantité de réfrigérant du banc est indiquée sur la plaque des données techniques qui se trouvent sur le banc. En cas de fuite de réfrigérant, éviter que des flammes nues ou des sources d'inflammation ne se trouvent à proximité du point de fuite.



Ne pas endommager le circuit réfrigérant.



afin de réduire les risques liés à l'inflammabilité, l'installation de cet appareil ne doit être effectuée que par du personnel adéquatement qualifié.



Ne pas endommager les parois internes ou externes de l'appareil: le circuit du fluide réfrigérant pourrait s'abîmer. En cas de parois endommagées, ne pas démarrer l'appareil et s'adresser à un centre d'assistance.

2.2 Avertissements généraux



Le constructeur décline toute responsabilité pour tout préjudice corporel ou matériel dû à un manque d'observation des avertissements contenus dans ce manuel. Toute personne utilisant ce meuble réfrigéré doit impérativement avoir lu le manuel de l'utilisateur.



L'employeur doit instruire ses personnels sur les risques d'accident, les dispositifs prévus pour la sécurité des personnels, les risques d'émissions sonores et les règles générales de prévention des accidents requises par la réglementation en vigueur.



Le meuble réfrigéré doit être utilisé par des adultes possédant les connaissances nécessaires et dont les capacités physiques, sensorielles ou mentales ne sont pas diminuées. Le meuble réfrigéré n'est pas destiné à être utilisé par des mineurs (en particulier de 0 à 3 ans). Il est de la responsabilité des adultes de surveiller les enfants afin qu'ils ne jouent pas avec le meuble réfrigéré.



Tout autre usage non explicitement indiqué dans ce manuel doit être considéré comme dangereux, et le constructeur ne pourra être tenu pour responsable d'éventuels dommages dérivant d'une utilisation impropre, erronée et non raisonnable.



Le meuble réfrigéré doit être utilisé par des personnels munis des équipements de protection individuelle appropriés.



Le port de gants de travail est obligatoire.



Ne pas laisser le meuble réfrigéré exposé aux agents atmosphériques.



Ne pas utiliser des jets d'eau directs ou indirects sur le meuble réfrigéré.





Ne pas toucher le meuble réfrigéré avec les mains ou les pieds mouillés ou humides, ne pas utiliser le meuble réfrigéré les pieds nus.

Modello - Modèle - Model Modell - Modelo - Modelo	EPTABRICKS 2.0 OUTDOOR	 Epta
Fabbricante - Constructeur - Manufacturer Hersteller - Fabricante - Fabricante	Epta Spa - Via Mecenate, 86 - 20138 Milano (MI) ITALIA Tel. 02/55403211 Telefax 02/55401023	4/27

User manual

IT
FR
EN
DE
ES
PT

 Le retrait de protections ou de panneaux requérant l'utilisation d'outils doit exclusivement être effectué par des personnels qualifiés.

 Ce meuble réfrigéré a été conçu pour l'utilisation, le transport et le stockage jusqu'à une altitude maximum de 2000 m au-dessus du niveau de la mer.

 Pour le montage d'accessoires dédiés, en option, veuillez vous adresser au service après-vente agréé le plus proche.

 Toute intervention doit exclusivement être effectuée par des personnels qualifiés. Dans tous les cas, avant toute intervention, couper impérativement l'alimentation électrique du meuble.

 Instruire toute personne utilisant le meuble sur la position de l'interrupteur-sectionneur.

 Le réglage du thermostat est réservé au personnel technique du service après-vente.

 Faire attention aux parties chaudes ou en mouvement marquées du symbole approprié.

 En cas d'incendie, ne pas utiliser de l'eau pour éteindre les flammes, mais exclusivement des extincteurs à sec.

 Le banc doit être posé à plat.

 Éviter les flammes ou les étincelles à l'intérieur de l'appareil.

 Veillez à ce que les fentes d'aération du caisson de l'appareil soient toujours bien dégagées.

 Ne pas utiliser d'appareils électriques à l'intérieur des compartiments de l'appareil pour la conservation des aliments congelés, si ceux-ci ne sont pas du type préconisé par le constructeur.

 Ne pas conserver de substances explosives ou dangereuses, telles que des récipients sous pression contenant du gaz propulseur inflammable, à l'intérieur de cet appareil.

 Ne pas poser de poids sur le toit du meuble réfrigéré; il est opportun d'éviter de placer des aliments non emballés directement sur les plateaux, veuillez utiliser des conteneurs pour aliments appropriés.

 Ne placez pas de contenants de liquide et ne versez pas de liquide sur le comptoir.

2.3 Avertissements pour l'entretien du meuble réfrigéré

 L'accès aux parties électriques et/ou aux parties nécessitant l'utilisation d'outils est réservé aux techniciens spécialisés.

 Avant toute opération d'entretien ou de nettoyage réservée à l'utilisateur, couper la tension au meuble en intervenant sur l'interrupteur-sectionneur général mural.

 Faire attention aux parties chaudes ou en mouvement marquées du symbole approprié.

 Le port de gants de travail est obligatoire.

Modello - Modèle - Model Modell - Modelo - Modelo	EPTABRICKS 2.0 OUTDOOR	
Fabbricante - Constructeur - Manufacturer Hersteller - Fabricante - Fabricante	Epta Spa - Via Mecenate, 86 - 20138 Milano (MI) ITALIA Tel. 02/55403211 Telefax 02/55401023	5/27

2.4 Avertissements électriques



S'assurer que la tension d'alimentation correspond aux caractéristiques de plaque du meuble.



L'installation électrique doit être effectuée dans les règles de l'art par des techniciens spécialisés.



Le retrait du couvercle du tableau électrique est réservé aux techniciens spécialisés.



Conformément aux règles d'installation, le réseau d'alimentation doit comporter un dispositif de déconnexion omnipolaire, assurant la déconnexion complète du secteur dans les conditions de surtension de catégorie III.



L'installation du meuble réfrigéré doit être effectuée conformément aux instructions du constructeur, par des personnels professionnellement qualifiés et dans le respect des normes sur les installations électriques en vigueur dans chaque pays.



Toute installation erronée du meuble réfrigéré risque de causer des préjudices aux personnes, aux animaux ou aux biens par rapport auxquels le constructeur décline toute responsabilité.



Si le cordon d'alimentation est endommagé, il doit être remplacé par du personnel de service autorisé. N'essayez pas de réparer le câble.



Ne pas alimenter le banc s'il est endommagé. En cas de doute, contactez le service après-vente ou votre revendeur.



Après avoir installé le banc, assurez-vous qu'il ne repose pas sur le câble d'alimentation.



Pour le branchement, n'utiliser en aucun cas des réductions, des rallonges, des adaptateurs ou des prises multiples. Le branchement doit se faire par conséquent de manière DIRECTE au réseau d'alimentation.

2.5 Interdictions



Il est interdit d'utiliser des dispositifs autres que ceux fournis par le constructeur dans le meuble réfrigéré, pour accélérer le dégivrage.



Il est interdit aux personnels non spécialisés de retirer le couvercle du tableau électrique ou d'ouvrir des panneaux nécessitant l'utilisation d'outils.



Il est interdit d'utiliser le meuble réfrigéré pour conserver et/ou exposer des substances explosives, inflammables ou corrosives, telles par exemple des bombes aérosol contenant un gaz propulseur inflammable.



Il est interdit d'utiliser le meuble réfrigéré pour conserver et/ou exposer des produits pharmaceutiques.



En cas de produits NON EMBALLÉS OU CONSERVÉS À BASSE TEMPÉRATURE, il est interdit d'utiliser le meuble réfrigéré pour conserver et/ou exposer des bouteilles et des emballages en verre.



Il est interdit d'installer le meuble réfrigéré dans un environnement contenant des substances gazeuses explosives.



Il est interdit de retirer la plaque du matricule du meuble réfrigéré.



Il est interdit de monter sur le comptoir ou sur le pare-chocs du comptoir.

Modello - Modèle - Model Modell - Modelo - Modelo	EPTABRICKS 2.0 OUTDOOR	
Fabbricante - Constructeur - Manufacturer Hersteller - Fabricante - Fabricante	Epta Spa - Via Mecenate, 86 - 20138 Milano (MI) ITALIA Tel. 02/55403211 Telefax 02/55401023	6/27

User manual

3. DESCRIPTION GÉNÉRALE

IT

FR

EN

DE

ES

PT

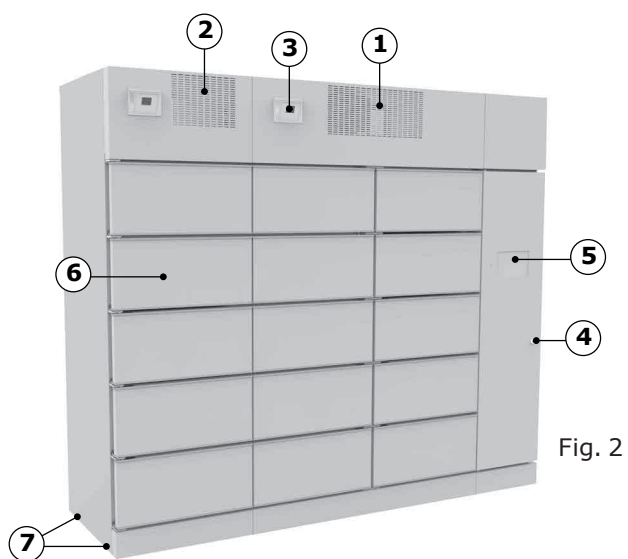

Fig. 2

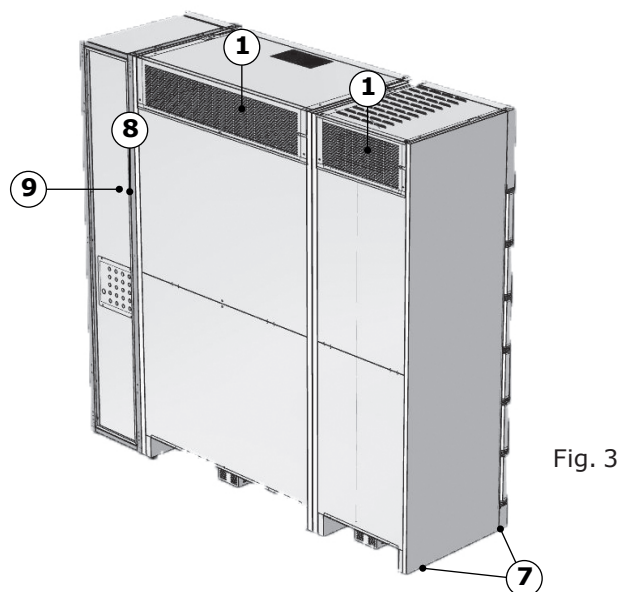

Fig. 3

1. Compartiment moteur
2. Couverture avant
3. Central électronique
4. Serrure
5. Display et Lecteur code qr
6. Portillons
7. Pieds réglables
8. Antenne filaire
9. Cordon d'alimentation

Modello - Modèle - Model Modell - Modelo - Modelo	EPTABRICKS 2.0 OUTDOOR	
Fabbricante - Constructeur - Manufacturer Hersteller - Fabricante - Fabricante	Epta Spa - Via Mecenate, 86 - 20138 Milano (MI) ITALIA Tel. 02/55403211 Telefax 02/55401023	7/27

3.1 Vues en coupe

EPTABRICKS OUTDOOR BT 5 DOORS

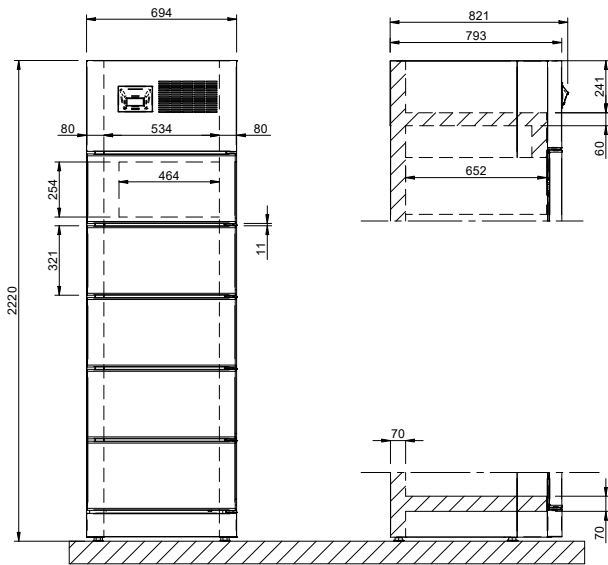

Fig. 4

EPTABRICKS OUTDOOR TN-AMBIENT 6 DOORS

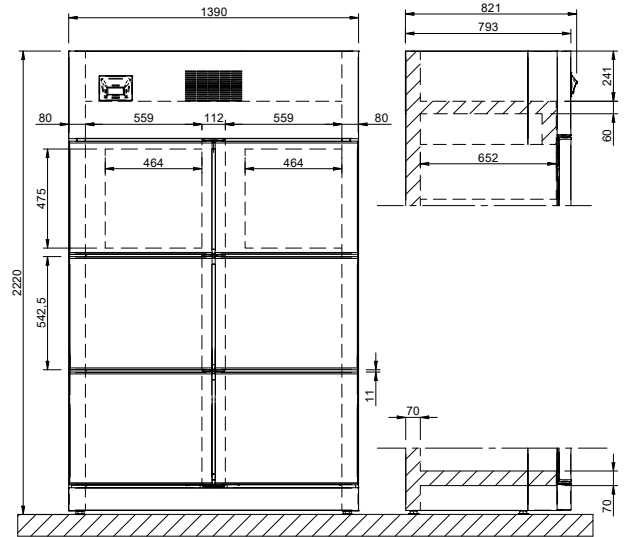

Fig. 6

EPTABRICKS OUTDOOR BT 6 DOORS

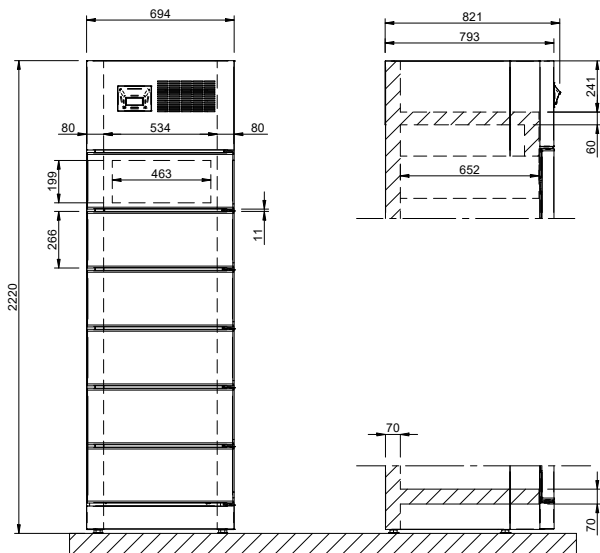

Fig. 5

EPTABRICKS OUTDOOR TN-AMBIENT 8 DOORS

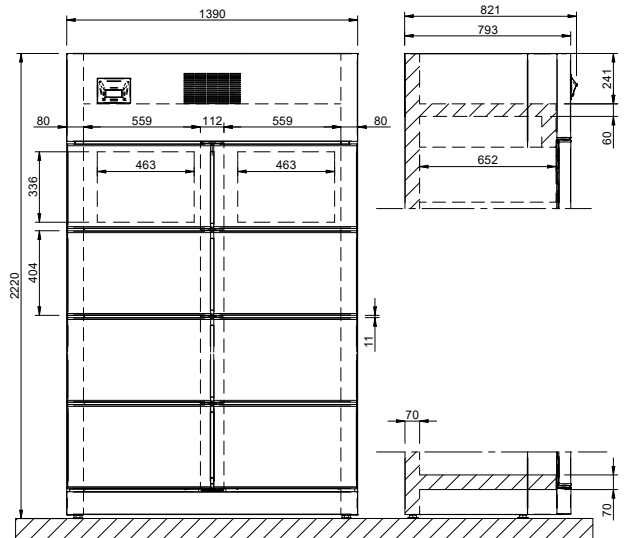

Fig. 7

Modello - Modèle - Model Modell - Modelo - Modelo	EPTABRICKS 2.0 OUTDOOR	
Fabbricante - Constructeur - Manufacturer Hersteller - Fabricante - Fabricante	Epta Spa - Via Mecenate, 86 - 20138 Milano (MI) ITALIA Tel. 02/55403211 Telefax 02/55401023	8/27

User manual

IT

FR

EN

DE

ES

PT

EPTABRICKS OUTDOOR TN-AMBIENT 10 DOORS EPTABRICKS OUTDOOR DRY 8 DOORS

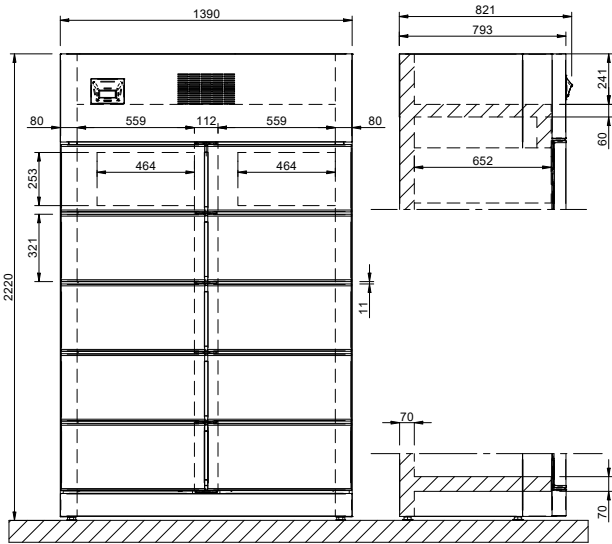

Fig. 8

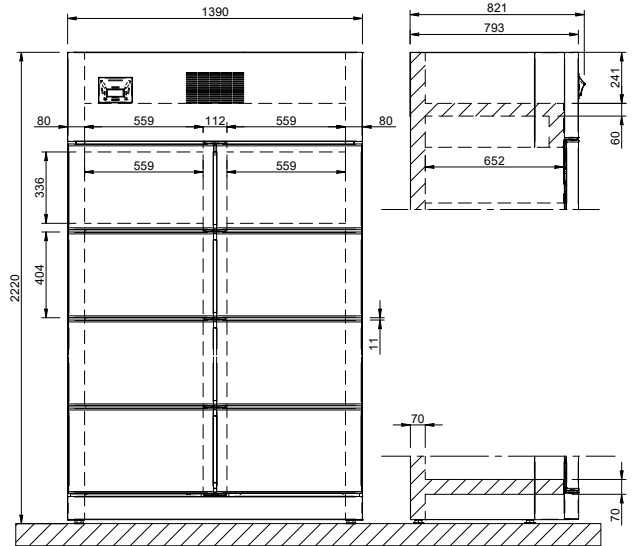

Fig. 10

EPTABRICKS OUTDOOR DRY 6 DOORS

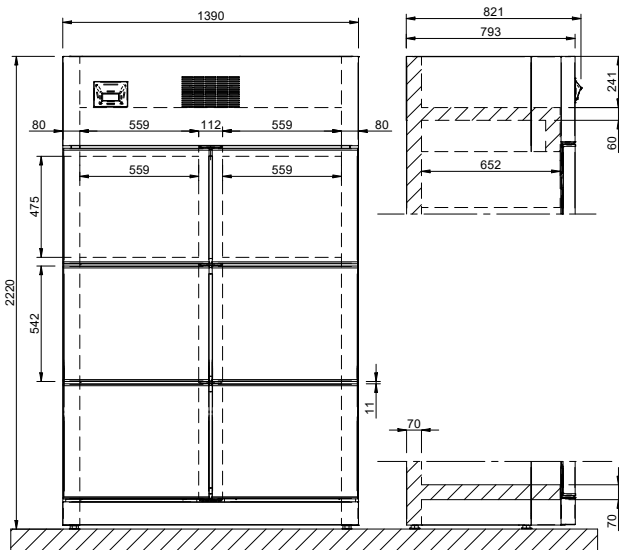

Fig. 9

EPTABRICKS OUTDOOR DRY 10 DOORS

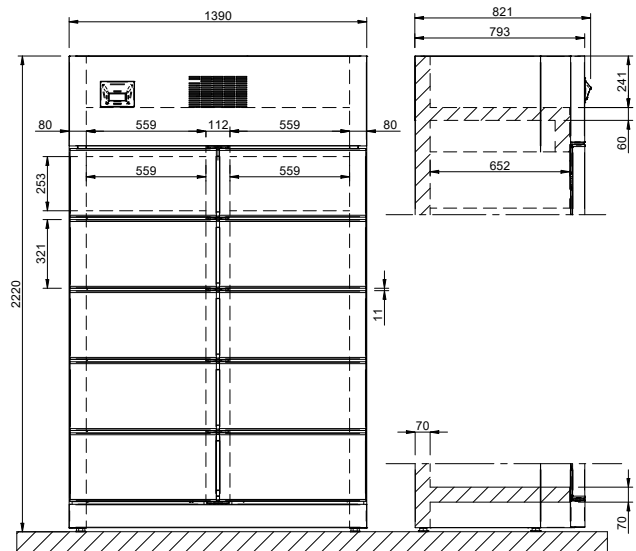

Fig. 11

Modello - Modèle - Model Modell - Modelo - Modelo	EPTABRICKS 2.0 OUTDOOR	
Fabbricante - Constructeur - Manufacturer Hersteller - Fabricante - Fabricante	Epta Spa - Via Mecenate, 86 - 20138 Milano (MI) ITALIA Tel. 02/55403211 Telefax 02/55401023	9/27

EPTABRICKS OUTDOOR MASTER

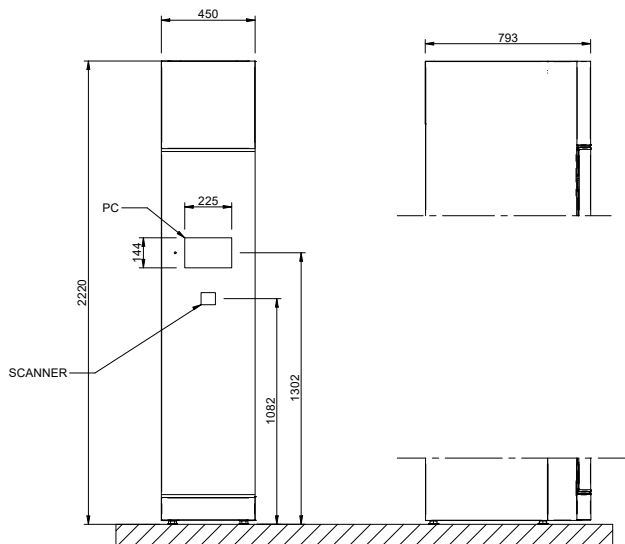

Fig. 12

IT

FR

EN

DE

ES

PT

Modello - Modèle - Model Modell - Modelo - Modelo	EPTABRICKS 2.0 OUTDOOR	
Fabbricante - Constructeur - Manufacturer Hersteller - Fabricante - Fabricante	Epta Spa - Via Mecenate, 86 - 20138 Milano (MI) ITALIA Tel. 02/55403211 Telefax 02/55401023	10/27

User manual

4. TRANSPORT DU MEUBLE RÉFRIGÉRÉ

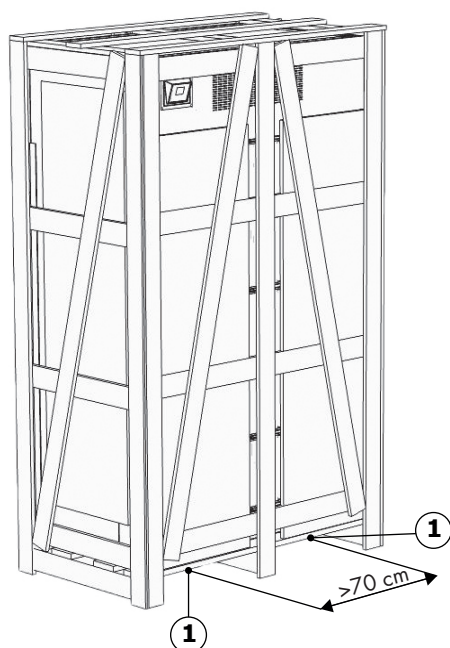

Fig. 13

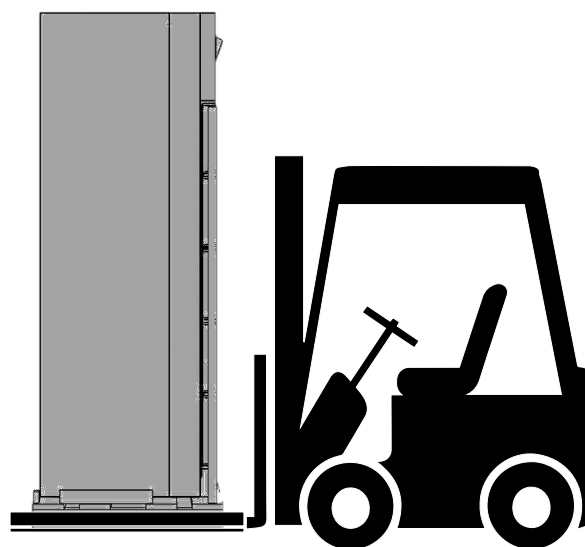

Fig. 14

1. Points de levage

Tab. I

Modèle	Poids (kg)	Poids avec emballage (kg)
EPTABRICKS OUTDOOR BT 5 DOORS	140	150
EPTABRICKS OUTDOOR BT 6 DOORS	140	150
EPTABRICKS OUTDOOR TN-AMBIENT 6 DOORS	250	263
EPTABRICKS OUTDOOR TN-AMBIENT 8 DOORS	250	263
EPTABRICKS OUTDOOR TN-AMBIENT 10 DOORS	250	263
EPTABRICKS OUTDOOR DRY 6 DOORS	135	145
EPTABRICKS OUTDOOR DRY 8 DOORS	135	145
EPTABRICKS OUTDOOR DRY 10 DOORS	135	145
EPTABRICKS OUTDOOR MASTER	90	100

Modello - Modèle - Model Modell - Modelo - Modelo	EPTABRICKS 2.0 OUTDOOR	 Epta
Fabbricante - Constructeur - Manufacturer Hersteller - Fabricante - Fabricante	Epta Spa - Via Mecenate, 86 - 20138 Milano (MI) ITALIA Tel. 02/55403211 Telefax 02/55401023	11/27

5. CONDITIONS AMBIANTES

IT

FR

EN

DE

ES

PT

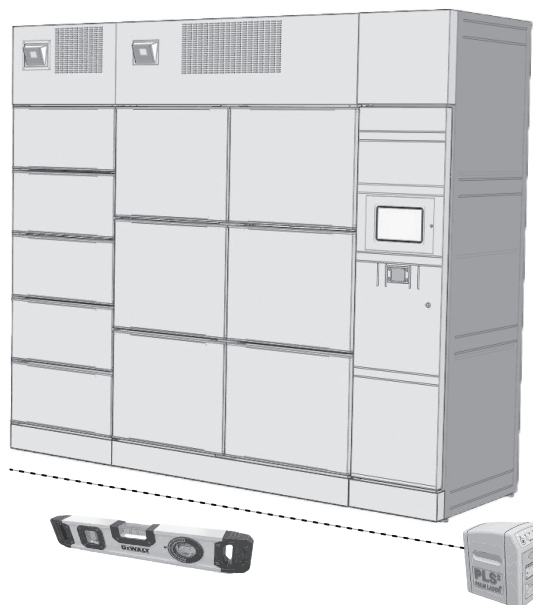

Fig. 15

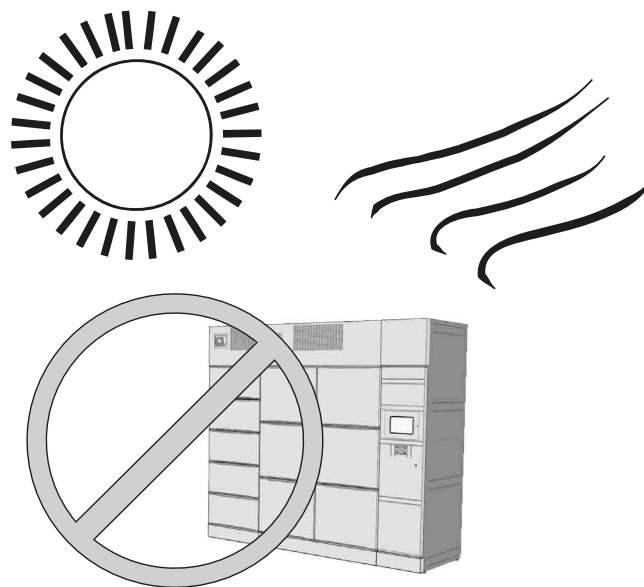

Fig. 17

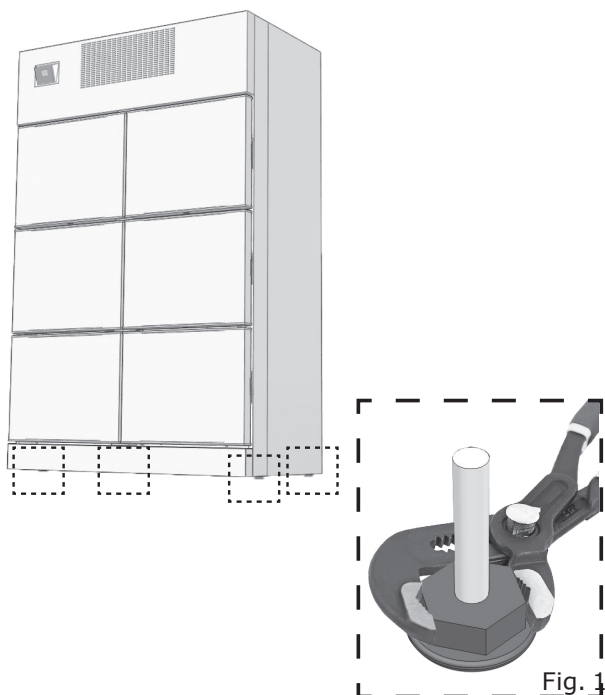

Fig. 16

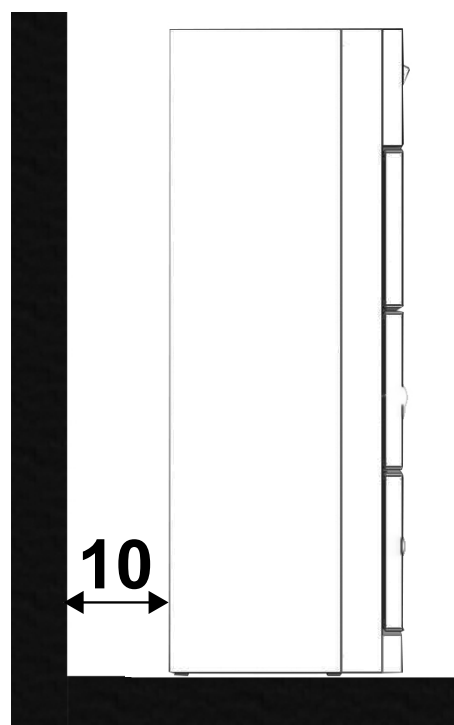

Fig. 18

Modello - Modèle - Model Modell - Modelo - Modelo	EPTABRICKS 2.0 OUTDOOR	
Fabbricante - Constructeur - Manufacturer Hersteller - Fabricante - Fabricante	Epta Spa - Via Mecenate, 86 - 20138 Milano (MI) ITALIA Tel. 02/55403211 Telefax 02/55401023	12/27

User manual

6. CONDITIONS AMBIANTES

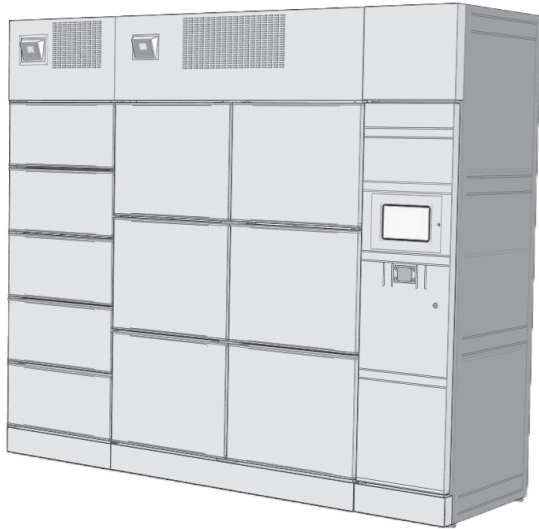

Fig. 19

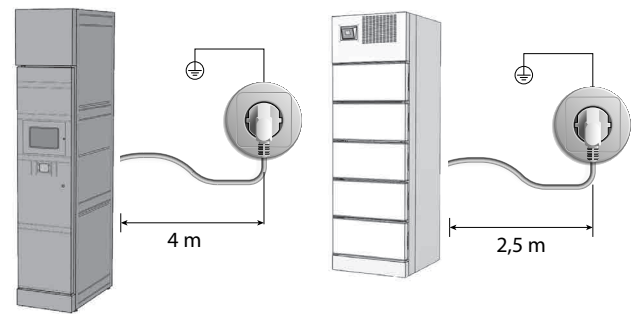

Fig. 20

Tab. II

Caractéristiques ambiantes	
Type	Valeur maximum
Température	35°C
Humidité relative	75 %

Modello - Modèle - Model Modell - Modelo - Modelo	EPTABRICKS 2.0 OUTDOOR	
Fabbricante - Constructeur - Manufacturer Hersteller - Fabricante - Fabricante	Epta Spa - Via Mecenate, 86 - 20138 Milano (MI) ITALIA Tel. 02/55403211 Telefax 02/55401023	13/27

7. CARACTÉRISTIQUES TECHNIQUES

 <small>EPTA S.p.A. Via Mecenate, 86 20138 Milano - Italy</small>		12	
1		2	
3		4	
5		6	
7		8	
9		10	
11		12	
13		14	
15		16	
17		18	
19		20	
21		22	
23		24	
25		26	

Fig. 21

- | | |
|-------------------------------------|------------------------------|
| 1. Origine du produit | 14. Date de fabrication |
| 2. Produit dans le "Pays d'origine" | 15. Code Hat |
| 3. Tension nominale | 16. Modèle |
| 4. Puissance nominale | 17. Type de réfrigérant 1 |
| 5. Fréquence nominale | 18. Masse réfrigérante 1 |
| 6. Courant nominal | 19. Type de réfrigérant 2 |
| 7. Puissance de dégivrage | 20. Masse réfrigérante 2 |
| 8. Courant et dégivrage | 21. Classe climatique |
| 9. Système de chauffe | 22. Isolation gaz |
| 10. Système d'éclairage | 23. Indice de protection |
| 11. Manuel de l'opérateur | 24. Marques de certification |
| 12. Code-barres | 25. Marque RAEE |
| 13. Numéro de série | |



Attention : contient du gaz réfrigérant inflammable.

Tab. III

Modèle	Quantité (g)
EPTABRICKS OUTDOOR BT	-
EPTABRICKS OUTDOOR TN	-
EPTABRICKS OUTDOOR AMBIENT	-

Modello - Modèle - Model Modell - Modelo - Modelo	EPTABRICKS 2.0 OUTDOOR	 Epta
Fabbricante - Constructeur - Manufacturer Hersteller - Fabricante - Fabricante	Epta Spa - Via Mecenate, 86 - 20138 Milano (MI) ITALIA Tel. 02/55403211 Telefax 02/55401023	14/27

User manual

8. UTILISATION DU MEUBLE RÉFRIGÉRÉ

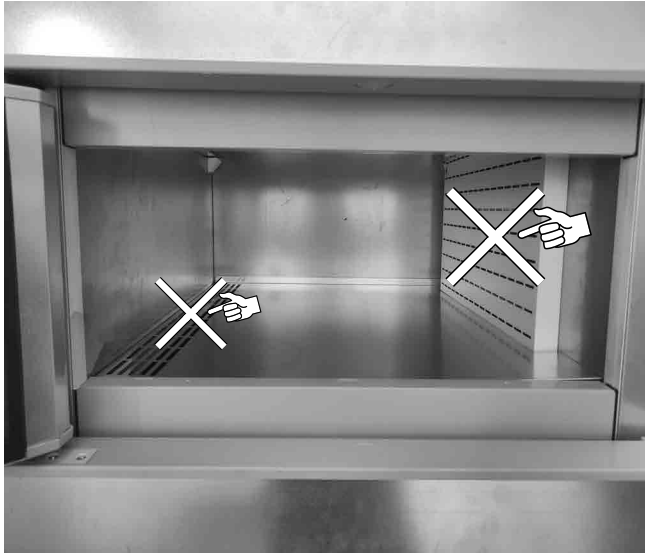

Fig. 22

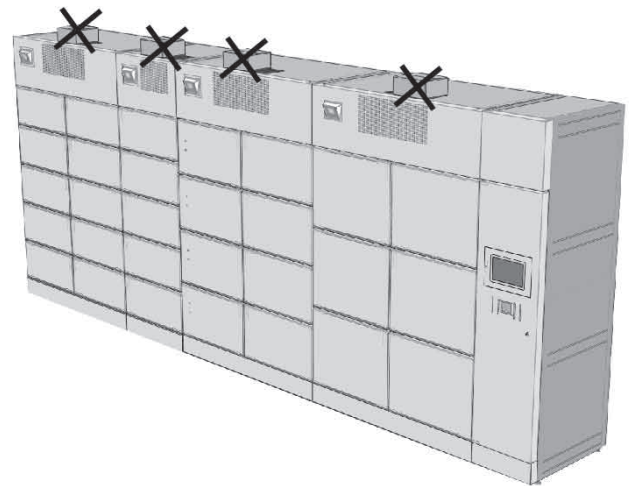

Fig. 24



Ne pas couvrir

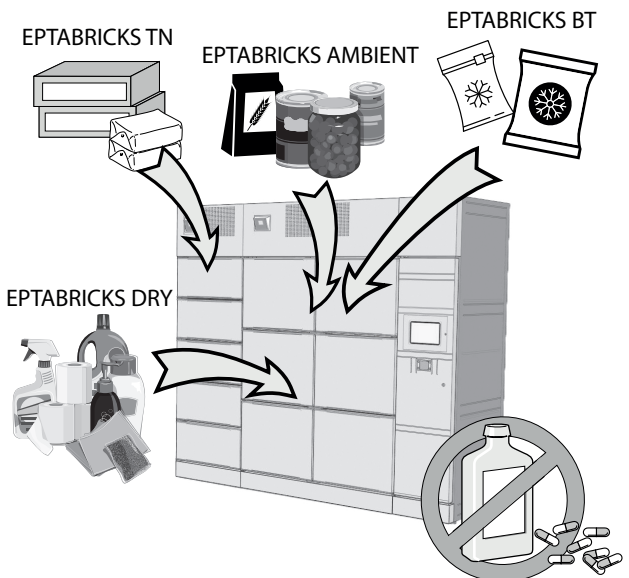

Fig. 23

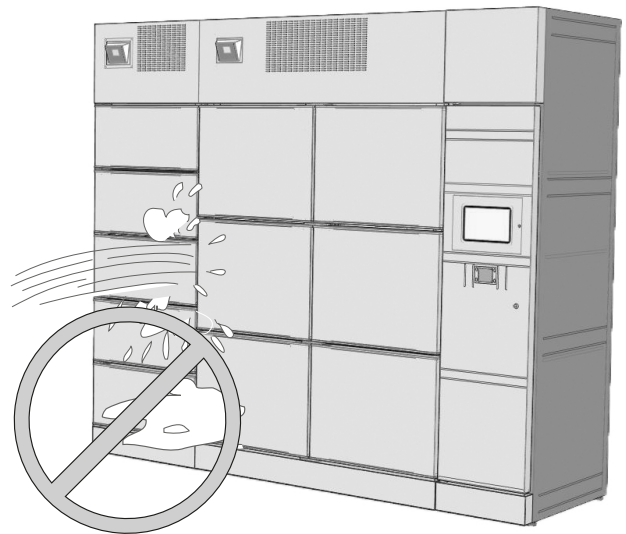

Fig. 25

Modello - Modèle - Model Modell - Modelo - Modelo	EPTABRICKS 2.0 OUTDOOR	 Epta
Fabbricante - Constructeur - Manufacturer Hersteller - Fabricante - Fabricante	Epta Spa - Via Mecenate, 86 - 20138 Milano (MI) ITALIA Tel. 02/55403211 Telefax 02/55401023	15/27

- IT
- FR**
- EN
- DE
- ES
- PT

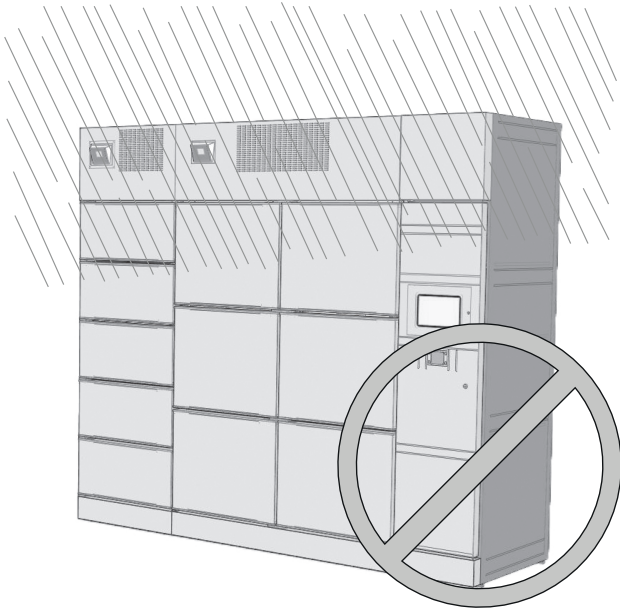

Fig. 26

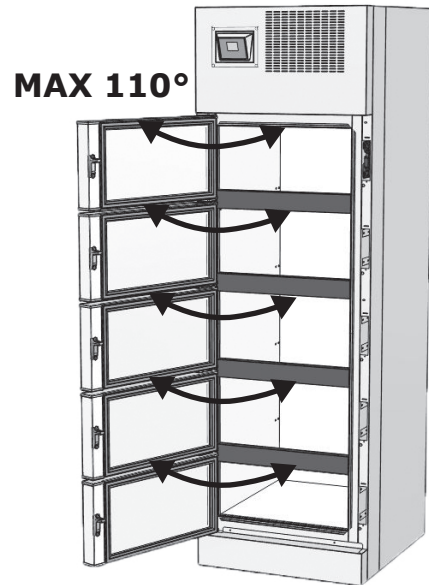

Fig. 28

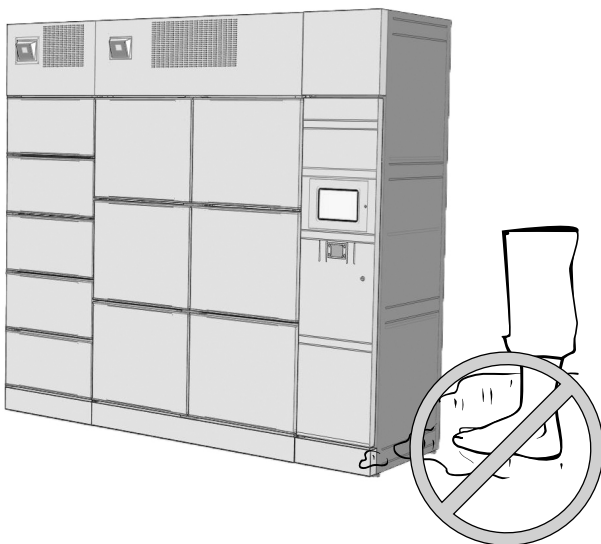

Fig. 27

Modello - Modèle - Model Modell - Modelo - Modelo	EPTABRICKS 2.0 OUTDOOR	 Epta
Fabbricante - Constructeur - Manufacturer Hersteller - Fabricante - Fabricante	Epta Spa - Via Mecenate, 86 - 20138 Milano (MI) ITALIA Tel. 02/55403211 Telefax 02/55401023	16/27

9. ENTRETIEN ORDINAIRE

9.1 Nettoyage du meuble réfrigéré

9.2 Nettoyage bac de collecte eau

- Dévisser et enlever la couverture inférieure et la couverture du bac.

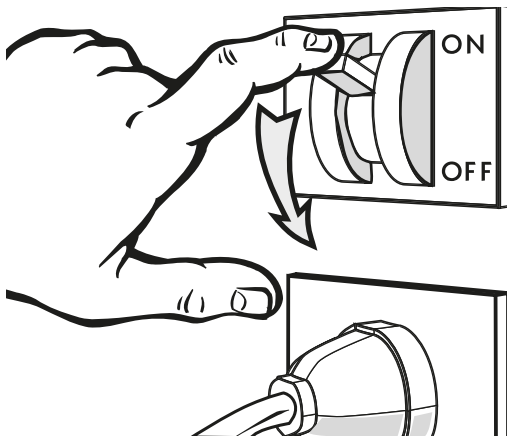

Fig. 29

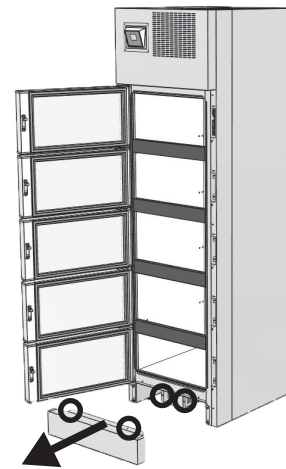

Fig. 31

- Extraire et nettoyer le bac.

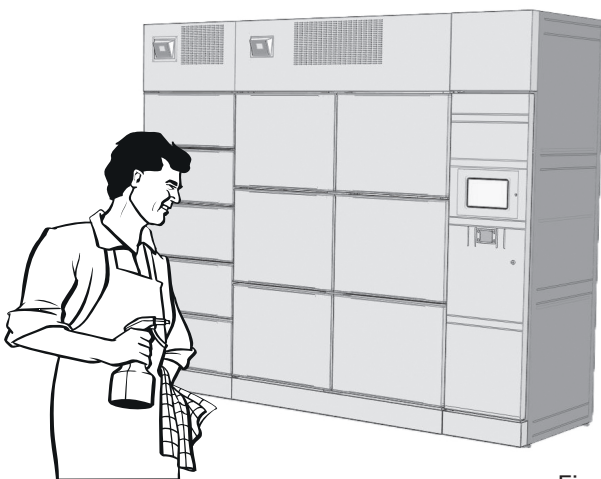

Fig. 30



Fig. 32



Nettoyer en fonction de l'usage et des besoins et en conditions d'environnement particulières (ex. forte humidité, température ambiante basse, présence de poussières) afin d'éviter une évaporation incorrecte et incomplète de l'eau et/ou la formation de mauvaises odeurs.

Modello - Modèle - Model Modell - Modelo - Modelo	EPTABRICKS 2.0 OUTDOOR	
Fabbricante - Constructeur - Manufacturer Hersteller - Fabricante - Fabricante	Epta Spa - Via Mecenate, 86 - 20138 Milano (MI) ITALIA Tel. 02/55403211 Telefax 02/55401023	17/27

10. INDICATIONS UTILISATEUR

10.1 Descriptions du meuble réfrigéré

Lea EPTABRICKS 2.0 OUTDOOR TN meuble a été conçu et fabriqué exclusivement pour l'exposition de denrées alimentaires fraîches préemballées, boissons et produits laitiers. L'appareil EPTABRICKS 2.0 OUTDOOR BT doit être utilisé exclusivement pour la vente de produits congelés.

L'appareil EPTABRICKS 2.0 OUTDOOR AMBIENT doit être utilisé exclusivement pour la vente de produits qui n'exigent pas de réfrigération à longue conservation.

L'appareil EPTABRICKS 2.0 OUTDOOR DRY è doit être utilisé exclusivement pour la vente de produits NO FOOD.

CLASSE DE TEMPÉRATURE EPTABRICKS 2.0 OUTDOOR TN (EN-ISO 23953-2): 7M2.

CLASSE DE TEMPÉRATURE EPTABRICKS 2.0 OUTDOOR BT (EN-ISO 23953-2): 7L1.

CLASSE DE TEMPÉRATURE EPTABRICKS 2.0 OUTDOOR AMBIENT (EN-ISO 23953-2): 7S.

Durant le transport, le déplacement, la réception, le stockage, l'installation, le chargement, l'utilisation, le nettoyage, l'entretien et le démantèlement, prêter particulièrement attention au risque de basculement du meuble ("Fig. 33").

Les caractéristiques générales et les dimensions sont illustrées dans les figures et les vues en coupe indiquées au chapitre "Description générale" (à la page "7").

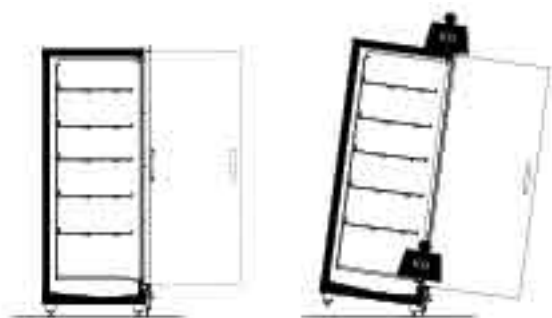

Fig. 33

10.2 Transport et déplacement

Le meuble réfrigéré est contenu dans un emballage spécial muni d'une plateforme pour le déplacement avec des chariots à fourche. Pour le transport et le déplacement du meuble réfrigéré, utiliser:

- exclusivement une plateforme prévue à cet effet ou équivalente
- Un chariot élévateur manuel ou électrique adapté au soulèvement du meuble, présentant des caractéristiques appropriées dans le respect des normes en vigueur

Le poids du meuble réfrigéré (vide et avec emballage) et les dimensions de l'emballage sont indiqués au chapitre "Transport du meuble réfrigéré" (tableau "Tab. I" et figures à la page "11").

Les opérations de déplacement doivent être effectuées par des personnels qualifiés, en mesure d'évaluer les poids, les points de levage et les moyens les plus adaptés, tant en ce qui concerne la sécurité que la portée.

10.3 Réception et stockage

Vérifier l'état de l'emballage avant de prendre livraison du meuble réfrigéré du transporteur. En cas de dommages évidents à l'emballage:

- Retirer l'emballage du meuble réfrigéré en présence du transporteur.
- Signer sous réserve le bon de livraison

Le constructeur ne répond pas des dommages éventuellement dus au transport ou à un stockage erroné du meuble réfrigéré.

Conserver le meuble dans un endroit l'abri di soleil et des intempéries, à une température comprise entre -25°C et +55°C et avec une humidité relative de l'air comprise entre 30% et 95%.

Modello - Modèle - Model Modell - Modelo - Modelo	EPTABRICKS 2.0 OUTDOOR	
Fabbricante - Constructeur - Manufacturer Hersteller - Fabricante - Fabricante	Epta Spa - Via Mecenate, 86 - 20138 Milano (MI) ITALIA Tel. 02/55403211 Telefax 02/55401023	18/27

10.4 Installation et conditions ambiantes

Ce meuble réfrigéré n'est pas conçu pour être installé à l'extérieur.

Pour que le meuble fonctionne correctement, vérifier qu'il est mis en place:

- Sur un sol nivelé ("Fig. 15").
- L'appareil a des pieds réglables pour l'arrêter et le positionner ("Fig. 16"). Il est absolument nécessaire, après le positionnement, de stabiliser l'appareil au sol.
- Il est important que le groupe motocompresseur placé dans la partie supérieure de la colonne soit toujours couvert par un auvent protecteur. Ne pas le laisser exposé directement à la pluie et aux intempéries. ("Fig.17").
- Il est essentiel de respecter les distances indiquées "Fig. 18" (cm) pour une installation correcte de l'appareil.

Assurer l'espace nécessaire à l'utilisation du meuble réfrigéré par la clientèle.

Les conditions du lieu où installer le meuble sont indiquées dans "Conditions ambiantes".

10.5 Connexion électrique



Si le comptoir réfrigéré a été fortement incliné en raison du positionnement des accessoires ou de montage, attendez au moins 3 heures avant la mise en service de manière à permettre à l'huile de recueillir dans le lubrifiant du compresseur. Si cette exigence n'est pas respectée, la machine de réfrigération de compression peut être irrémédiablement endommagée.



LA LIGNE D'ALIMENTATION ÉLECTRIQUE À LAQUELLE SERA BRANCHÉ LE RÉFRIGÉRATEUR DOIT ÊTRE PROTÉGÉE PAR UN INTERRUPTEUR DIFFÉRENTIEL MAGNÉTOTHERMIQUE À HAUTE SENSIBILITÉ (In=16 A, Id = 30 mA) ET BRANCHÉE À L'INSTALLATION GÉNÉRALE DE MISE À LA TERRE. La mise à la terre est nécessaire et obligatoire pour un bon fonctionnement de l'appareil.

Installer un interrupteur-sectionneur omnipolaire en amont du meuble réfrigéré. L'interrupteur-sectionneur doit avoir:

- Écart minimum entre les contacts 3 mm
- Pouvoir d'interruption adapté

Le câble doit être bien tendu, dans une position à l'abri des chocs, loin des substances liquides, de l'eau ou des sources de chaleur. Il ne doit pas être endommagé.

L'interrupteur-sectionneur doit être mis en place dans une position permettant d'être actionné aisément dans des situations d'urgence (distance maximum de 3 m).

Avant de brancher le meuble réfrigéré, s'assurer que la tension d'alimentation correspond aux caractéristiques de plaque du meuble. Pour garantir un fonctionnement régulier, la variation de tension maximale doit être comprise entre +/- 6% de la valeur nominale.

10.6 Caractéristiques techniques

La plaque matricule contient les caractéristiques techniques du meuble réfrigéré. Sa position et les caractéristiques sont indiquées dans "Caractéristiques techniques" ("Fig. 21").

Les schémas électriques, les listes d'étalonnage des instruments de contrôle, les instructions d'installation et une copie de la Déclaration de Conformité sont disponibles sur le site <https://documents.eptarefrigeration.com>.

Le niveau de pression sonore générée par le fonctionnement du meuble est inférieur à 70 dB(A). Le meuble réfrigéré ne produit pas de vibrations nuisibles.

Modello - Modèle - Model Modell - Modelo - Modelo	EPTABRICKS 2.0 OUTDOOR	 Epta
Fabbricante - Constructeur - Manufacturer Hersteller - Fabricante - Fabricante	Epta Spa - Via Mecenate, 86 - 20138 Milano (MI) ITALIA Tel. 02/55403211 Telefax 02/55401023	19/27

10.7 Chargement du produit

Mettre le meuble sous tension pour démarrer son cycle de refroidissement, en intervenant sur l'interrupteur-sectionneur général mural. Après environ 2 heures vous pouvez charger la marchandise dans le meuble réfrigéré.

Le meuble réfrigéré est en mesure de maintenir la température de la marchandise, mais non de l'abattre. Les denrées alimentaires ne doivent donc être placées à l'intérieur du meuble que si elles ont déjà été refroidies à leur température de conservation respective. Ne jamais placer de produits chauds dans le meuble réfrigéré.

Lors du stockage de la marchandise, s'assurer que:

- le chargement est homogène par ses dimensions et la qualité de la marchandise
- La marchandise ne bouche pas le flux d'air réfrigéré ("Fig. 22")
- Pour une bonne conservation du produit, maintenir une distance de 10 cm environ de la partie supérieure du compartiment portillon.



Angle d'ouverture maximum de la porte = 110°. Pour un fonctionnement correct et pour éviter d'éventuels affaissements et/ou problématiques, il ne faut pas forcer l'ouverture des portillons pour un angle supérieur à 110°.

Charge maximale admissible uniformément distribuée: 32 Kg .

10.8 Accès

Informations pour l'accès

Le modèle EptaBricks a un logiciel installé par EPTA sur chaque point de collecte.

Dans ce manuel, on décrit l'accès au logiciel par le biais de :

- Profil client
- Profil préposé livraisons

Chaque profil a des droits, nécessités et donc une vision différente du menu.

Attention! La serrure portillon est dotée d'un contrôle magnétique ; en cas de portillon ouvert, l'ouverture sera signalée avec une alarme.

Profil client - Retrait produits

La colonne MASTER permet le retrait des commandes, aussi bien par le biais de balayage/saisie du numéro de commande que par le biais du balayage/saisie de la carte fidélité.

Dans le cas de la carte de fidélité, si le client a plusieurs commandes dans les portillons, une page-écran spécifique apparaîtra dans la liste des commandes qui peuvent être collectées.

Les portillons s'ouvrent un à la fois ; pour ouvrir le portillon suivant, il faut fermer le portillon précédent.

A la fin du retrait, le client a la possibilité de:

- Terminer le retrait donc retour à la page-écran initiale.
- Ouvrir à nouveau les portillons (si le client craint d'avoir oublié un article).

Si un problème devait se vérifier durant la réinitialisation, un message approprié sera affiché pour le client. Cette page-écran est personnalisée en fonction du point de vente.

- Accéder au retrait produit en pressant la touche blanche centrale.



#EPTABricks
24/7

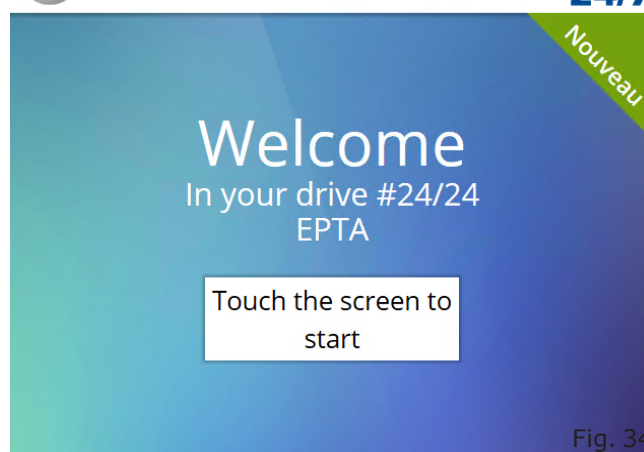

Fig. 34

Modello - Modèle - Model Modell - Modelo - Modelo	EPTABRICKS 2.0 OUTDOOR	
Fabbricante - Constructeur - Manufacturer Hersteller - Fabricante - Fabricante	Epta Spa - Via Mecenate, 86 - 20138 Milano (MI) ITALIA Tel. 02/55403211 Telefax 02/55401023	20/27

User manual

- IT
- FR
- EN
- DE
- ES
- PT

- Saisir le numéro commande sur la droite de l'écran ou bien scanner le code QR.

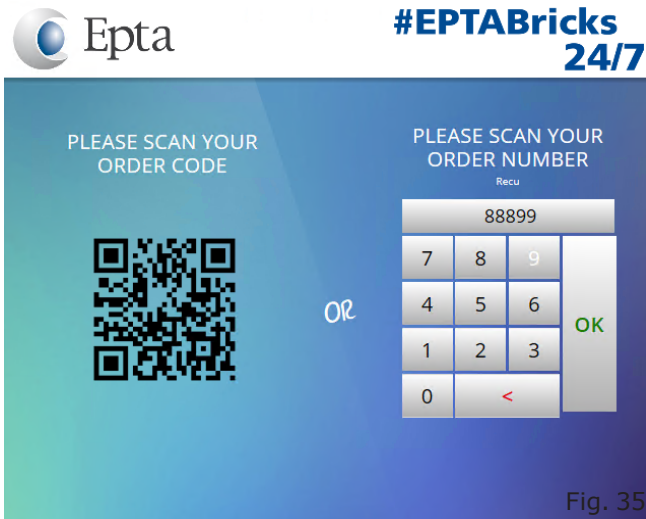

- Presser si le retrait de la marchandise est terminée, ou bien si on veut encore contrôler le portillon.



- Retirer la marchandise du portillon signalé sur l'écran de la colonne MASTER. Une fois la marchandise retirée, veuillez former le portillon.

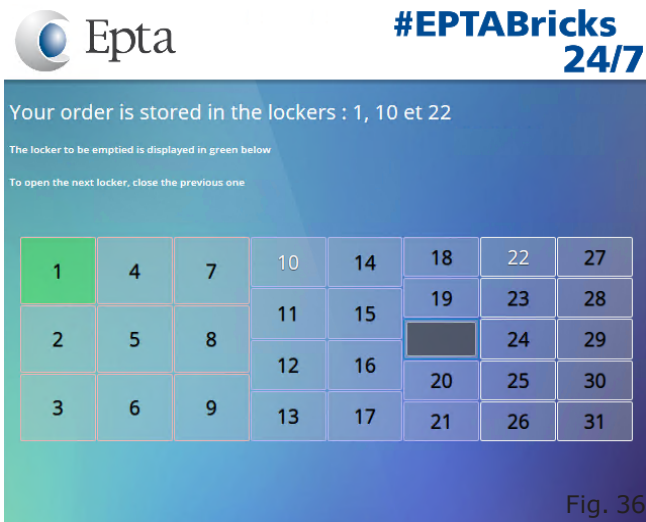

Profil préposé livraisons - Chargement produit

La création, l'activation et la désactivation des comptes livraison se font directement dans le terminal de collecte. Chaque préposé aux livraisons dispose d'un numéro d'identification univoque avec lequel il peut effectuer le balayage ou bien accéder au terminal. Le livreur peut visualiser combien de portes sont libres, la présence d'alarmes et choisir la modalité de livraison:

- Auto-Allocation: La première porte s'ouvre automatiquement et, à la fermeture, la porte successive s'ouvrira.
- No Auto-Allocation: Le livreur choisit quelle porte ouvrir en cliquant sur elle.

Modello - Modèle - Model Modell - Modelo - Modelo	EPTABRICKS 2.0 OUTDOOR	 Epta
Fabbricante - Constructeur - Manufacturer Hersteller - Fabricante - Fabricante	Epta Spa - Via Mecenate, 86 - 20138 Milano (MI) ITALIA Tel. 02/55403211 Telefax 02/55401023	21/27

- Accéder au chargement produit en pressant la touche blanche centrale.



Fig. 38

- Visualiser les portes libres, choisir la modalité de livraison et appuyer la touche "Chargement".

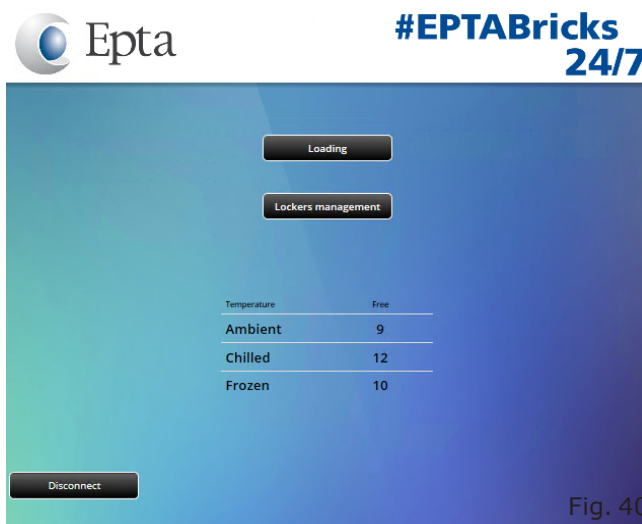

Fig. 40

- Scanner / Saisir le numéro d'identification du préposé au chargement

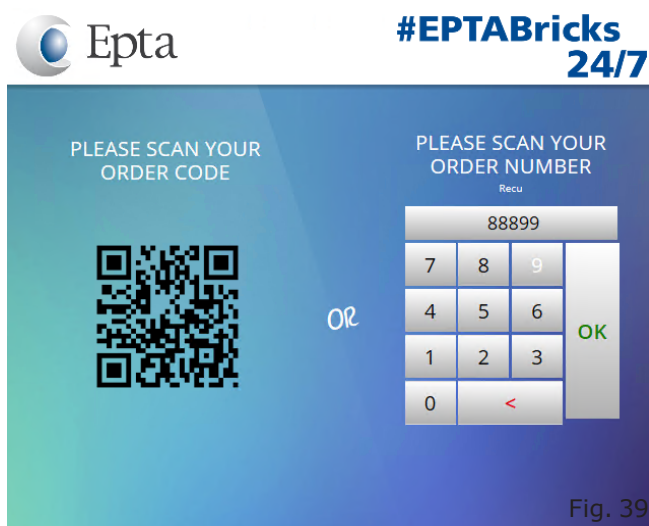

Fig. 39

- Saisir le numéro de commande de la marchandise et presser OK.

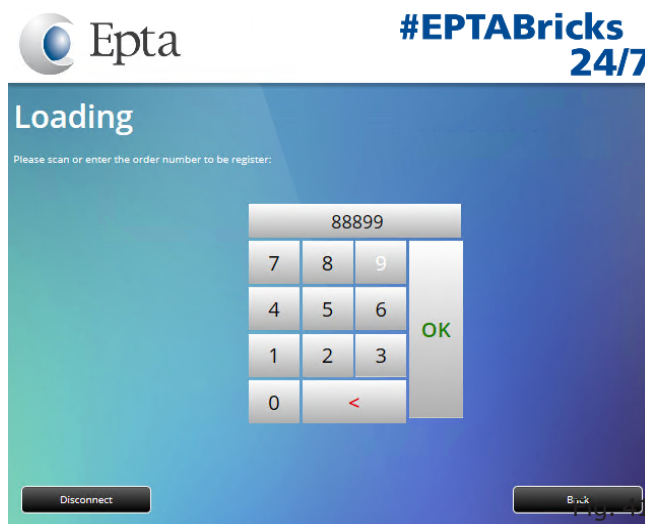

Fig. 41

Modello - Modèle - Model Modell - Modelo - Modelo	EPTABRICKS 2.0 OUTDOOR	
Fabbricante - Constructeur - Manufacturer Hersteller - Fabricante - Fabricante	Epta Spa - Via Mecenate, 86 - 20138 Milano (MI) ITALIA Tel. 02/55403211 Telefax 02/55401023	22/27

User manual

IT

FR

EN

DE

ES

PT

- Le portillon à charger s'activera et s'ouvrira. Dès que le portillon est chargé, veuillez le fermer.

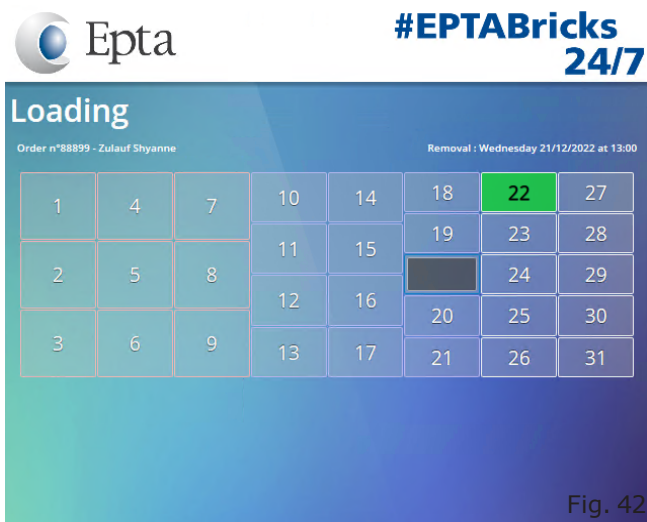

- Une fois les portillons attribués à la commande terminés, on peut ajouter des portillons supplémentaires en pressant la touche en bas à droite.

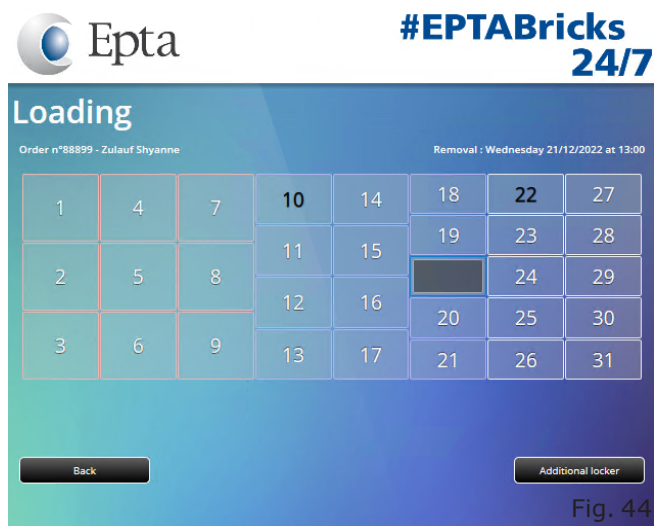

- Si la commande exige le chargement de plusieurs portillons (cause quantité ou exigences de température), lors de la fermeture du portillon prélèvement, le suivant s'ouvrira.

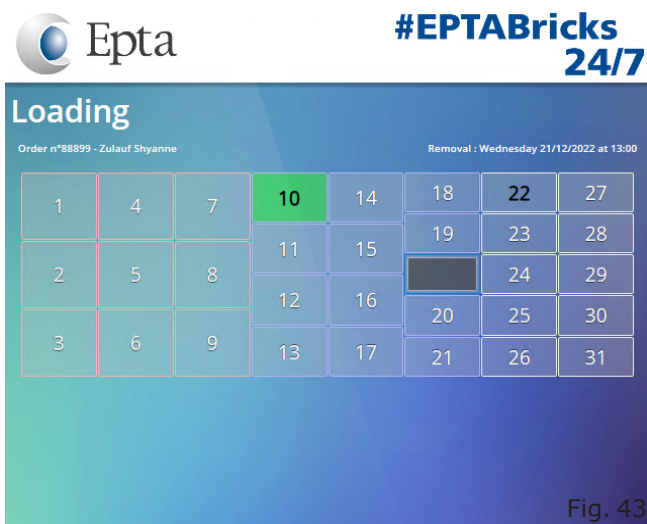

- Sélectionner la typologie de portillon que l'on veut ajouter.

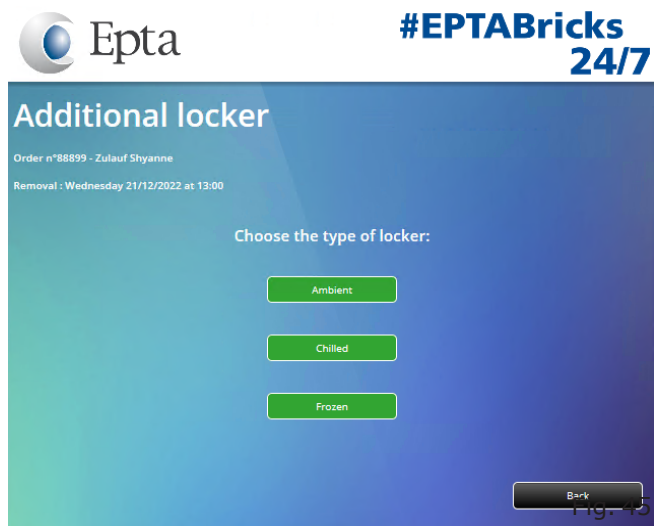

Modello - Modèle - Model Modell - Modelo - Modelo	EPTABRICKS 2.0 OUTDOOR	 Epta
Fabbricante - Constructeur - Manufacturer Hersteller - Fabricante - Fabricante	Epta Spa - Via Mecenate, 86 - 20138 Milano (MI) ITALIA Tel. 02/55403211 Telefax 02/55401023	23/27

- Le portillon supplémentaire demandé s'activera et s'ouvrira. Dès que le portillon est chargé, veuillez le fermer.

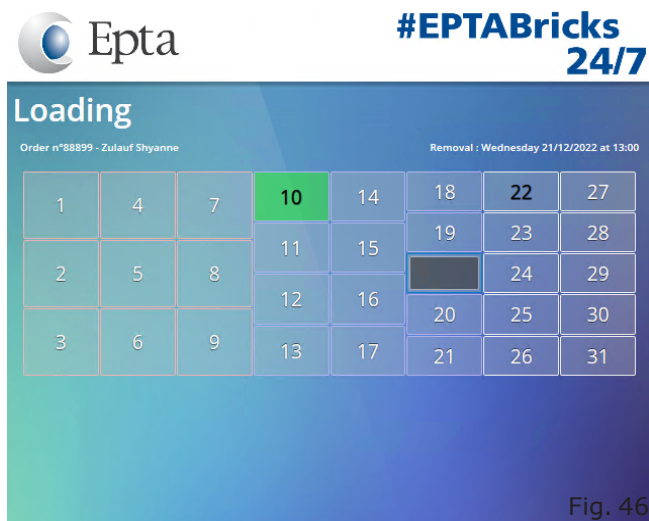

Fig. 46

- Si on souhaite ajouter un portillon supplémentaire, presser encore la touche en bas à droite. Si en revanche la commande a été complètement chargée, presser la touche en bas à gauche.

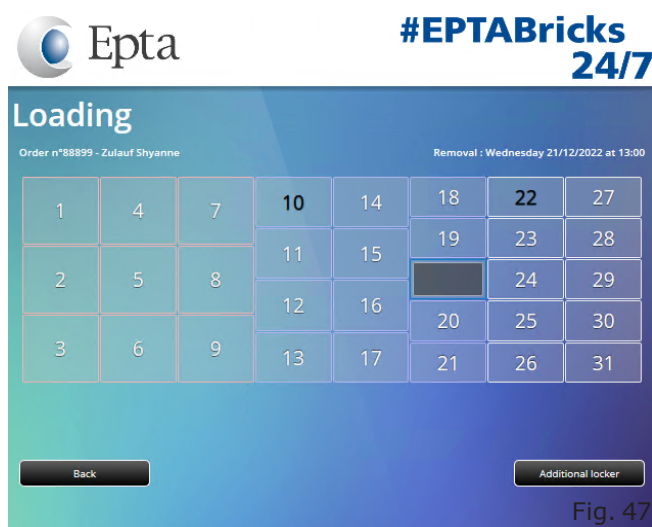

Fig. 47

10.9 Nettoyage et entretien ordinaire

Il est recommandé d'assurer une bonne visibilité dans la zone d'intervention, éventuellement en utilisant une source d'éclairage supplémentaire.

Nettoyage du meuble réfrigéré

Utiliser exclusivement de l'eau à la température maximum de 65°C et du savon ou un produit détergent ménager neutre dilué dans l'eau.

Veillez absolument de ne pas utiliser:

- d'éponges abrasives
- de produits inflammables ou abrasifs tels que l'alcool, l'acétone ou les solvants
- des détergents contenant des tensioactifs non ioniques, du citron ou du vinaigre (acide acétique)



Ne pas laver ou nettoyer la partie supérieure du meuble avec de l'eau ou des liquides.

Nettoyer **UNE FOIS PAR SEMAINE** toutes les parties extérieures du meuble:

ÉCRAN TACTILE: Ne jamais utiliser de solvants d'aucun type, ne jamais verser d'eau directement sur l'écran. Humidifier légèrement un chiffon en coton et le passer sur l'écran pour éliminer la saleté ou le matériau étranger. Bien sécher l'écran et essuyer l'écran avec un chiffon en microfibre.

Nettoyer **UNE FOIS PAR MOIS** toutes les parties intérieures du meuble, en suivant les instructions indiquées ci-dessous:

- Couper la tension électrique au meuble réfrigéré en intervenant sur l'interrupteur-sectionneur général mural ("Fig. 29").
- Vider le meuble réfrigéré en stockant la marchandise en chambre froide ou dans des réfrigérateurs aptes à maintenir leur température de conservation.
- Attendre que l'intérieur du meuble réfrigéré soit à la température ambiante avant de commencer le nettoyage
- Après avoir vérifié attentivement que l'intérieur du meuble est complètement sec, remettre en fonction l'appareil en le mettant sous tension.
- Attendre environ deux heures avant de charger la marchandise.

Modello - Modèle - Model Modell - Modelo - Modelo	EPTABRICKS 2.0 OUTDOOR	 Epta
Fabbricante - Constructeur - Manufacturer Hersteller - Fabricante - Fabricante	Epta Spa - Via Mecenate, 86 - 20138 Milano (MI) ITALIA Tel. 02/55403211 Telefax 02/55401023	24/27

User manual

IT
FR
EN
DE
ES
PT

Pour mettre le meuble hors service, débrancher l'alimentation et suivre la marche indiquée ci-dessus, en laissant les portes ouvertes (si disponible) pour éviter les odeurs désagréables.

TOUS LES TROIS MOIS effectuer le dégivrage du meuble afin d'éliminer la glace qui s'est éventuellement formée sur les ailettes de l'évaporateur en empêchant son bon fonctionnement. La durée et le nombre de dégivrages sont directement réglés d'origine. D'autres réglages éventuels sont exclusivement réservés au service après-vente et au service technique. L'eau de dégivrage est collectée dans une cuve spéciale et acheminée vers un bac de dissipation. Vérifier périodiquement que l'eau de dégivrage s'écoule normalement.

Nettoyage bac de collecte eau

Attention! Nettoyer en fonction de l'usage et des besoins et en conditions d'environnement particulières (ex. forte humidité, température ambiante basse, présence de poussières) afin d'éviter une évaporation incorrecte et incomplète de l'eau et/ou la formation de mauvaises odeurs.

10.10 Situations d'urgence

Le meuble réfrigéré ne démarre pas ou s'arrête:

- Vérifier l'absence de blackout électrique.
- Vérifier que l'interrupteur général mural est branché.
- Vérifier que la fiche du meuble réfrigéré est branchée dans la prise secteur.

Si la coupure électrique n'est pas due à ces raisons, contactez le service après-vente agréé le plus proche, retirez complètement tous les produits et stockez-les immédiatement en chambre froide ou dans des réfrigérateurs aptes à maintenir la température de conservation.

Le meuble réfrigéré ne refroidit pas suffisamment:

- Vérifier que le condenseur est propre et qu'il est en mesure d'exercer sa fonction d'échangeur thermique; effectuer un nettoyage soigneux si les ailettes sont bouchées.
- S'assurer que le meuble est chargé correctement.
- Dégivrer le meuble et reprendre ensuite son fonctionnement normal, si cette opération n'a pas été effectuée depuis plus de trois mois.
- Vérifier que le meuble réfrigéré n'est pas placé près de sources de chaleur ou de courants d'air.
- Vérifier les conditions ambiantes indiquées au chapitre "Conditions ambiantes" ("Tab. II").
- Vérifier la planéité du meuble réfrigéré à l'aide d'un niveau.
- S'assurer de la fermeture parfaite de la porte

Si le meuble ne refroidit toujours pas, contactez le service après-vente agréé le plus proche.

Modello - Modèle - Model Modell - Modelo - Modelo	EPTABRICKS 2.0 OUTDOOR	
Fabbricante - Constructeur - Manufacturer Hersteller - Fabricante - Fabricante	Epta Spa - Via Mecenate, 86 - 20138 Milano (MI) ITALIA Tel. 02/55403211 Telefax 02/55401023	25/27

Le meuble réfrigéré est bruyant:

- Vérifier que les vis et les boulons sont parfaitement serrés.
- Vérifier la planéité du meuble réfrigéré à l'aide d'un niveau.

Si l'inconvénient persiste, contactez le service après-vente agréé le plus proche.

10.11 Service après-vente

En cas de nécessité d'intervention de techniciens, contactez immédiatement le fournisseur chez qui vous avez acheté le meuble réfrigéré.

En cas de nécessité d'utiliser des pièces de rechange, toujours contacter le service après-vente: demandez et assurez-vous que les pièces de rechange fournies sont d'origine.

10.12 Démantèlement et élimination

AVERTISSEMENTS POUR L'ÉLIMINATION CORRECTE DU PRODUIT AUX TERMES DE LA DIRECTIVE EUROPÉENNE 2012/19/UE

Pour des raisons inhérentes à la protection de l'environnement, et en conformité avec ce qui est disposé par la Directive 2011/65/EC, les meubles pour produits réfrigérés et surgelés doivent être au terme de leur cycle de vie éliminés et recyclés de façon appropriée.

En s'assurant que cela soit fait, l'utilisateur contribue à prévenir de façon significative les potentielles conséquences sur l'environnement et la santé.

Les meubles avec installation de réfrigération et équipés de fiche d'alimentation (et donc prêts à l'installation), sont définis WEEE: "Waste Electrical and Electronic Equipment" (déchets des équipements électriques et électroniques).

- Conférer les meubles aux centres appropriés spécialisés dans la récupération et le recyclage des WEEE.
- En alternative, rendre les meubles au revendeur ou au constructeur.
- Dans tous les cas la récupération des WEEE à soumettre à des opérations de traitement doit être effectuée en adoptant des critères qui garantissent la protection des appareillages utilisés seulement durant le transport et les opérations de chargement et de déchargement. Ne pas laisser les appareils sans surveillance même peu de jours.
- Eviter d'endommager le circuit de réfrigération qui contient des fluides avec de potentiels effets nuisibles sur l'écosystème et sujets à des prescriptions particulières.
- S'assurer de la fermeture des portillons et fixer de façon adéquate les parties mobiles.
- Débrancher la fiche d'alimentation des appareillages hors d'usage et couper le câble d'alimentation de manière à les rendre inutilisables.

Le symbole reporté sur la plaque matriculaire du meuble et sur la documentation d'accompagnement, indique que:

Modello - Modèle - Model Modell - Modelo - Modelo	EPTABRICKS 2.0 OUTDOOR	 Epta
Fabbricante - Constructeur - Manufacturer Hersteller - Fabricante - Fabricante	Epta Spa - Via Mecenate, 86 - 20138 Milano (MI) ITALIA Tel. 02/55403211 Telefax 02/55401023	26/27

User manual

- IT
- FR
- EN
- DE
- ES
- PT

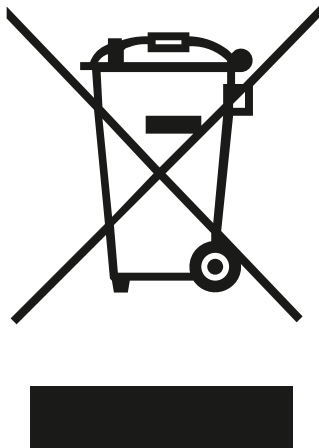

Fig. 48

- le produit a été mis en circulation après la date du 13 août 2005;
- le produit est sujet à la "collecte différenciée", ne doit pas être traité comme déchet ménager et ne peut être conféré en décharge.

Pour de plus amples informations sur le traitement, la récupération et le recyclage de ce produit, contacter le bureau local approprié, le service de ramassage des déchets ménagers ou le revendeur chez qui le produit a été acheté.
ON DÉCLARE QUE LE MEUBLE EST CONFORME À LA DIRECTIVE RoHS 2011/65/EC.



L'appareil contient huile, gaz caloporteur inflammable, parties en plastique et parties métalliques. L'appareil contient huile, gaz caloporteur inflammable, parties en plastique et parties métalliques. Attention! L'isolation polyuréthane utilise de la mousse CYCLOPENTANE, gaz naturel sans effet sur l'environnement, mais inflammable. Pour garantir le plus grand respect des normes sur l'environnement, il est recommandé de ne jamais se débarrasser de l'appareil. Ne jetez pas l'emballage de votre appareil dans la poubelle, mais trier les différents matériaux comme: le polystyrène, le carton, les sachets en plastique etc.. La démolition de l'appareil et la récupération des matériaux composants doit se passer en respectant les normes en vigueur en cette matière.

En cas d'appareil hors d'usage:

- Retirer la fiche d'alimentation.
- Couper le câble d'alimentation et l'éliminer avec la fiche.
- Ne pas extraire les tiroirs ni les différents composants à l'intérieur du bac, de façon à rendre plus difficile pour les enfants d'entrer dans le compartiment réfrigéré de l'appareil.
- Les enfants n'ont pas le droit de jouer avec l'appareil éliminé. Danger d'asphyxie!
- L'appareil contient du gaz inflammable à l'intérieur du circuit de refroidissement qui doit être éliminé de façon appropriée. Il faut éviter d'endommager les parties du circuit de refroidissement durant l'élimination de l'appareil.

Ne jamais couper ou séparer les composants du circuit de réfrigération avant d'avoir vidangé le circuit et avoir fait récupérer le réfrigérant par des personnels qualifiés.

Modello - Modèle - Model Modell - Modelo - Modelo	EPTABRICKS 2.0 OUTDOOR	
Fabbricante - Constructeur - Manufacturer Hersteller - Fabricante - Fabricante	Epta Spa - Via Mecenate, 86 - 20138 Milano (MI) ITALIA Tel. 02/55403211 Telefax 02/55401023	27/27

11. AVERTISSEMENTS GÉNÉRAUX SUPPLÉMENTAIRES

Instructions pour une installation et un entretien corrects

Les instructions d'utilisation et d'entretien sont indiquées dans le manuel de l'utilisateur disponible dans notre site web:

www.eptarefrigeration.com.

Des instructions d'installation pour le personnel expérimenté sont disponibles:

- Après de notre réseau après-vente
- Dans certaines catégories de produits, sous forme papier, livrées avec le produit

Services professionnels de réparation.

Les services sont fournis par notre réseau après-vente qui peut être consulté dans l'espace Contacts à l'adresse web www.eptarefrigeration.com.

Pièces de rechange

Les pièces de rechange et les informations pour la réparation de l'appareil sont disponibles pendant au moins 8 ans après la mise hors production du produit à l'adresse web suivantewww.epta-service.com/service.

Les identifiants d'accès sont fournis en adressant une demande par e-mail à: servicesupport@eptarefrigeration.com.

Nettoyage du condenseur à air

Les appareils à groupe logé avec condensation à air ne conservent leur efficacité que si le nettoyage du condenseur est effectué de la manière et aux périodicités indiquées dans le manuel d'utilisation et d'entretien.

Informations importantes sur les gaspillages alimentaires

Il est recommandé de suivre attentivement les instructions de conservation figurant sur l'emballage des produits, ainsi que les indications fournies par les producteurs de produits alimentaires.

Par conséquent, les paramétrages de la température doivent être adaptés aux caractéristiques de conservation des produits alimentaires, conformément aux indications contenues dans notre documentation technique.

Toute utilisation incorrecte peut entraîner une détérioration.

Conditions ambiantes

Cet appareil est destiné à fonctionner dans des environnements où la température et l'humidité se situent dans les limites indiquées dans le manuel d'utilisation.

Instructions pour le désassemblage

Pour le désassemblage, veuillez vous adresser à des opérateurs professionnels.

Portant depuis toujours une attention particulière à l'environnement, le Groupe Epta met à la disposition des utilisateurs des manuels de démantèlement et de traitement des déchets des meubles réfrigérés à groupe logé, téléchargeables ci-dessous.

- Manuel de démantèlement des meubles réfrigérés à groupe logé ouverts:



- Manuel de démantèlement des meubles réfrigérés à groupe logé fermés:



Autres informations

Pour plus d'informations, veuillez faire référence à www.eptarefrigeration.com et à EPREL en scannant le code QR ci-contre ou sur l'étiquette énergie du produit.



Modello - Modèle - Model Modell - Modelo - Modelo	EPTABRICKS 2.0 OUTDOOR	
Fabbricante - Constructeur - Manufacturer Hersteller - Fabricante - Fabricante	Epta Spa - Via Mecenate, 86 - 20138 Milano (MI) ITALIA Tel. 02/55403211 Telefax 02/55401023	1/27

VERZEICHNIS

1. Einführung	2	IT
2. Sicherheitshinweise	3	FR
2.1 Warnhinweise für Geräte mit R290 (Propan) und R600a (Isobutan)	3	EN
2.2 Allgemeine Hinweise	3	DE
2.3 Wartungshinweise für das Kühlmöbel	4	ES
2.4 Elektrische Warnhinweise	5	PT
2.5 Verbote	5	
3. Allgemeine Beschreibung	6	
3.1 Schnittbilder	7	
4. Transport des Kühlmöbels	10	
5. Umgebungsbedingungen	11	
6. Umgebungsbedingungen	12	
7. Technische eigenschaften	13	
8. Verwendung des Kühlmöbels	14	
9. Wartung des möbels	16	
9.1 Die Reinigung des Kühlmöbels	16	
9.2 Reinigung wasserspeicherwanne	16	
10. Hinweise für den Nutzer	17	
10.1 Beschreibung des Kühlmöbels	17	
10.2 Transport und Bewegung des Kühlmöbels	17	
10.3 Empfang und Lagerung des Möbels	17	
10.4 Installation und Umgebungsbedingungen	18	
10.5 Elektrischer Anschluss	18	
10.6 Technische eigenschaften	18	
10.7 Die Befüllung des Kühlmöbels	19	
10.8 Zugang	19	
10.9 Reinigung und regelmäßige Wartung	23	
10.10 Gefahrensituationen	24	
10.11 Technischer Wartungsdienst	25	
10.12 Demontage und Entsorgung	25	
11. Allgemeine ergänzende Hinweise	27	

VERWENDETE SYMBOLE

Symbol für ein Verbot: Verbietet bestimmte Handlungen.



Gefahrensymbol: Regeln zur Unfallvermeidung für den Benutzer.



Symbol für einen Warnhinweis: Möglicherweise kann ein Schaden an der Kühlzellentür oder/und einer ihrer Komponenten entstehen



Symbol für einen Hinweis: Es folgen nützliche Informationen.

Modello - Modèle - Model Modell - Modelo - Modelo	EPTABRICKS 2.0 OUTDOOR	
Fabbricante - Constructeur - Manufacturer Hersteller - Fabricante - Fabricante	Epta Spa - Via Mecenate, 86 - 20138 Milano (MI) ITALIA Tel. 02/55403211 Telefax 02/55401023	2/27

1. EINFÜHRUNG

Es wird empfohlen, den Inhalt des vorliegenden Handbuchs zu lesen und es gemeinsam mit dem Kühlmöbel aufzubewahren.

Der Hersteller lehnt jede Haftung für Personen- oder Sachschäden ab, die durch Nichtbeachtung der in diesem Handbuch enthaltenen Warnhinweise entstehen.



Abb. 1

Das vorliegende Handbuch enthält Informationen, die für die ordnungsgemäße Verwendung und Funktionsweise des Kühlmöbels notwendig sind.

Es enthält die folgenden Erläuterungen und Informationen:

- Eine Funktionsbeschreibung des Kühlmöbels, inklusive all seiner Komponenten
- Informationen über die für dieses Gerät geltenden Sicherheits- und Unfallverhütungsvorschriften
- Hinweise zur korrekten Verwendung des Kühlmöbels
- Hinweise für die korrekte, routinemäßige und planmäßige Wartung, einschließlich der Reinigungsarbeiten

Für die korrekte Installation des Kühlmöbels verweisen wir auf die folgenden Dokumente:

- Quick Reference Instructions

Das vorliegende Handbuch richtet sich an die folgenden Berufsgruppen:

- **QUALIFIZIERTE MITARBEITER:** Qualifizierte Personen, die mit dem Betrieb, der Einstellung, der Reinigung und der regelmäßigen Wartung des Möbels betraut sind
- **SPEZIALISIERTE TECHNIKER:** Techniker, die von der im Vertrag angegebenen Stelle (Hersteller/Vertragshändler/Lieferfirma) geschult und befugt sind, die folgenden Arbeiten auszuführen: Installation, außerordentliche Wartung, Reparatur, Austausch und Inspektion des Kühlmöbels

Die Bedienungsanleitung ist auch unter verfügbar:

www.eptarefrigeration.com.

Die geltenden Vorschriften und Zertifizierungen für dieses Kühlmöbel entnehmen Sie bitte der Konformitätserklärung.

Bewahren Sie die Gebrauchsanweisung und für den Fall des Verkaufs immer auf.

Modello - Modèle - Model Modell - Modelo - Modelo	EPTABRICKS 2.0 OUTDOOR	
Fabbricante - Constructeur - Manufacturer Hersteller - Fabricante - Fabricante	Epta Spa - Via Mecenate, 86 - 20138 Milano (MI) ITALIA Tel. 02/55403211 Telefax 02/55401023	3/27

2. SICHERHEITSHINWEISE

2.1 Warnhinweise für Geräte mit R290 (Propan) und R600a (Isobutan)



Isobutan und Propan sind natürliche Gase ohne Umweltauswirkungen, allerdings entzündbar. Es ist daher unbedingt darauf zu achten, dass alle Leitungen im Kühlkreislauf unbeschädigt sind, bevor die Kühltheke an das Stromnetz angeschlossen wird. Der Raum, in dem die Theke aufgestellt wird, muss ein Mindestvolumen von 1m³ für jedes 8g Kältemittel haben. Die Menge des Kältemittels in der Theke ist auf dem Typenschild der Theke angegeben. Im Falle eines Kältemittellecks sind offene Flammen oder Zündquellen in der Nähe der Leckstelle zu vermeiden.



Beschädigen Sie nicht den Kühlkreislauf.



ein blitzschlag im stromversorgungsnetz oder in der nähe der anlage kann bei ungünstigen bedingungen das ausschalten der lampen verursachen und das eingreifen eines technikers erforderlich machen



Beschädigen sie nicht die inneren und äusseren wände des geräts: der kühlmittelkreislauf könnte beschädigt werden. Im fall von beschädigten gerätewänden schalten sie das gerät nicht ein und wenden sie sich an ein kundendienstzentrum.

2.2 Allgemeine Hinweise



Der Hersteller lehnt jede Haftung für Personen- oder Sachschäden ab, die durch Nichtbeachtung der in diesem Handbuch enthaltenen Warnhinweise entstehen. Jede Person, die dieses Kühlmöbel verwendet, ist dazu aufgefordert, das vorliegende Benutzerhandbuch zu lesen.



Der Arbeitgeber muss das Personal über die folgenden geltenden Vorschriften informieren: Über die Unfallgefahren, über die bestehenden Sicherheitsvorrichtungen für das Personal, über die Gefahren von Lärmemissionen und die allgemeinen Unfallverhütungsvorschriften.



Dieses Kühlmöbel darf nur von Erwachsenen benutzt werden, die über die erforderlichen Kenntnisse verfügen und deren körperliche, sensorischen oder geistigen Fähigkeiten nicht beeinträchtigt sind; das Gerät ist nicht für die Benutzung durch Minderjährige (insbesondere 0 bis 3 Jahre alt) geeignet. Kinder dürfen auch unter der Aufsicht und Verantwortung von Erwachsenen nicht mit dem Kühlmöbel spielen.



Jede andere nicht ausdrücklich in diesem Handbuch angegebene Verwendungen gelten als gefährlich. Soit kann der Hersteller nicht für Schäden haftbar gemacht werden, die durch falschen Anschluss, fehlerhafte oder nicht bestimmungsgemäße Verwendung verursacht wurden.



Das Kühlmöbel darf nur von Personen benutzt werden, die mit der entsprechenden, passenden Schutzkleidung ausgestattet sind.



Das Tragen von Handschuhen ist Vorschrift.



Das Kühlmöbel darf keinen Witterungseinflüssen ausgesetzt werden.



Das Kühlmöbel darf keinem direkten oder indirekten Wasserstrahl ausgesetzt werden.





Berühren Sie das Kühlmöbel nicht mit nassen oder feuchten Händen oder Füßen. Benutzen Sie das Gerät niemals barfuß.

Modello - Modèle - Model Modell - Modelo - Modelo	EPTABRICKS 2.0 OUTDOOR	
Fabbricante - Constructeur - Manufacturer Hersteller - Fabricante - Fabricante	Epta Spa - Via Mecenate, 86 - 20138 Milano (MI) ITALIA Tel. 02/55403211 Telefax 02/55401023	4/27

User manual

IT
FR
EN
DE
ES
PT

 Das Entfernen von Schutzvorrichtungen oder von Teilen der Verkleidung, für das der Einsatz von Werkzeug erforderlich ist, ist ausschließlich qualifiziertem Personal vorbehalten.

 Dieses Gerät ist für den Einsatz, den Transport und die Lagerung bis zu einer maximalen Höhe von 2000 m über dem Meeresspiegel ausgelegt.

 Wenden Sie sich bitte an das nächstgelegene autorisierte Servicezentrum, um spezielle Zusatzausstattungen montieren zu lassen.

 Sämtliche Arbeiten sind ausschließlich durch qualifiziertes Personal durchzuführen. Das Gerät muss vor jedem Eingriff von der Stromzufuhr getrennt werden.

 Weisen Sie jeden, der das Kühlmöbel benutzt, auf die Position des Trennschalters hin.

 Eingriffe am Thermostat sind ausschließlich dem autorisierten technischen Kundendienst vorbehalten.

 Achten Sie auf warme oder bewegliche Geräteteile. Diese sind mit einem entsprechenden Symbol gekennzeichnet.

 Verwenden Sie im Falle eines Brandes ausschließlich Trockenlöschgeräte, verwenden Sie kein Wasser zum Löschen der Flammen.

 Das gerät muss waagrecht aufgestellt werden.

 Vermeiden Sie Flammen oder Funken im Inneren des Geräts.

 Die Lüftungsöffnungen am Gehäuse des Geräts müssen stets frei bleiben.

 Verwenden Sie keine elektrischen Geräte in den Tiefkühlfächern des Möbels, wenn diese nicht dem vom Hersteller empfohlenen Typ entsprechen.

 Lagern Sie in diesem Gerät keine explosiven oder gefährlichen Stoffe, wie z.B. unter Druck stehende Behälter mit entflammbarem Treibmittel.

 Es dürfen keine Lasten auf das Kühlregal oben positioniert werden; Unverpackte Lebensmittel sollten nicht direkt ins Regal gelegt werden. Diese sollten in dafür geeignete Behälter gelegt werden.

 Stellen Sie keine Flüssigkeitsbehälter auf und gießen Sie keine Flüssigkeiten auf die Theke.

2.3 Wartungshinweise für das Kühlmöbel

 Der Zugriff auf die elektrischen Komponenten und/oder auf Teile, die den Einsatz von Werkzeug erfordern, ist qualifizierten Technikern vorbehalten.

 Vor der Durchführung von Wartungs- oder Reinigungsarbeiten muss die Stromzufuhr zum Kühlmöbel über Hauptschalter unterbrochen werden.

 Achten Sie auf warme oder bewegliche Geräteteile. Diese sind mit einem entsprechenden Symbol gekennzeichnet.

 Das Tragen von Handschuhen ist Vorschrift.

Modello - Modèle - Model Modell - Modelo - Modelo	EPTABRICKS 2.0 OUTDOOR	
Fabbricante - Constructeur - Manufacturer Hersteller - Fabricante - Fabricante	Epta Spa - Via Mecenate, 86 - 20138 Milano (MI) ITALIA Tel. 02/55403211 Telefax 02/55401023	5/27

2.4 Elektrische Warnhinweise



Vergewissern Sie sich, dass die Versorgungsspannung den Angaben auf dem Typenschild des Kühlmöbels entspricht.



Die Elektroinstallation muss von fachkundigen Technikern fachgerecht ausgeführt werden.



Die Abdeckung der Schalttafel darf nur durch qualifizierte Techniker entfernt werden.



Gemäß den Installationsvorschriften muss das Stromversorgungsnetz über eine allpolige Trennvorrichtung verfügen, die unter den Betriebsbedingungen der Überspannungskategorie III die vollständige Trennung vom Netz gewährleistet.



Die Installation des Kühlmöbels muss gemäß den Anweisungen des Herstellers durch qualifiziertes Personal erfolgen. Dabei müssen die im jeweiligen Bestimmungsland des Kühlmöbels geltenden Vorschriften für elektrische Betriebsmittel eingehalten werden.



Eine fehlerhafte Installation des Kühlmöbels kann Schäden an Personen, Tieren oder Dingen verursachen, für die der Hersteller nicht haftbar gemacht werden kann.



Wenn das Netzkabel beschädigt ist, muss es von autorisiertem Servicepersonal ersetzt werden. Versuchen Sie nicht, das Kabel zu reparieren.



Versorgen Sie die Bank nicht mit Strom, wenn sie beschädigt ist. Wenden Sie sich im Zweifelsfall an den Kundendienst oder Ihren Händler.



Stellen Sie nach der Installation der Bank sicher, dass sie nicht auf dem Netzkabel aufliegt.



Verwenden Sie für den Stromanschluss auf keinen Fall Reduzierstecker, Verlängerungskabel, Adapter oder Steckerleisten. Der Netzanschluss muss folglich DIREKT ausgeführt werden.

2.5 Verbote



Es ist verboten, andere als die vom Hersteller im Kühlmöbel mitgelieferten Geräte zu verwenden, um den Abtauvorgang zu beschleunigen.



Das Entfernen der Schalttafelabdeckung oder das Öffnen von Abdeckungen, die den Einsatz von Werkzeug erfordern, ist für nicht qualifiziertes Personal verboten.



Es ist verboten, das Kühlmöbel zur Aufbewahrung und/oder Präsentation von explosiven, entflammenden oder ätzenden Stoffen einzusetzen, wie z. B. Sprühdosen mit entflammbarem Treibmittel.



Das Kühlmöbel darf nicht für die Aufbewahrung und/oder Auslage von Arzneimitteln verwendet werden.



BEI UNVERPACKTEN PRODUKTEN ODER BEI NIEDRIGEN TEMPERATUREN ist es verboten, dieses Kühlmöbel zur Lagerung und/oder Präsentation von Flaschen und Verpackungen aus Glas zu verwenden.



Es ist verboten, das Kühlmöbel in einer Umgebung aufzustellen, in der sich explosive, gasförmige Stoffe befinden.



Es ist verboten, das Typenschild des Kühlmöbels zu entfernen.



Das Betreten der Theke oder der Thekenstoßstange ist verboten.

IT

FR

EN

DE

ES

PT

Modello - Modèle - Model Modell - Modelo - Modelo	EPTABRICKS 2.0 OUTDOOR	
Fabbricante - Constructeur - Manufacturer Hersteller - Fabricante - Fabricante	Epta Spa - Via Mecenate, 86 - 20138 Milano (MI) ITALIA Tel. 02/55403211 Telefax 02/55401023	6/27

User manual

3. ALLGEMEINE BESCHREIBUNG

IT

FR

EN

DE

ES

PT



Abb. 2



Abb. 3

1. Motorraum
2. Vorderseite
3. Elektronische Steuereinheit
4. Schloss
5. Display und Lesevorrichtung qr code
6. Türen
7. Verstellbare füsse
8. Drahtantenne
9. Netzkabel

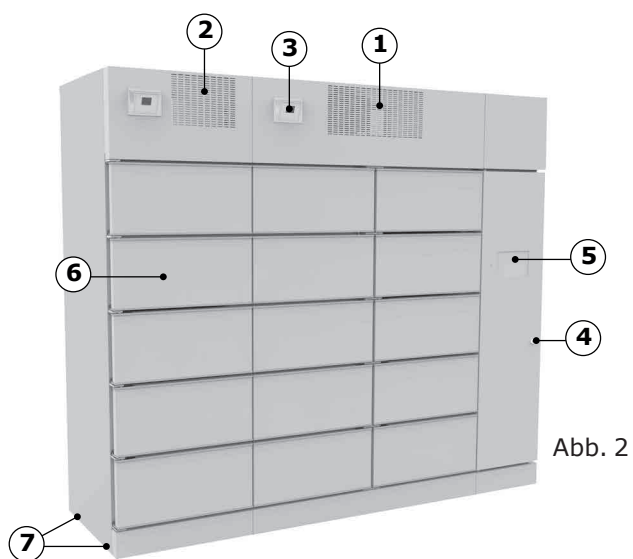
Modello - Modèle - Model Modell - Modelo - Modelo	EPTABRICKS 2.0 OUTDOOR	
Fabbricante - Constructeur - Manufacturer Hersteller - Fabricante - Fabricante	Epta Spa - Via Mecenate, 86 - 20138 Milano (MI) ITALIA Tel. 02/55403211 Telefax 02/55401023	7/27

3.1 Schnittbilder

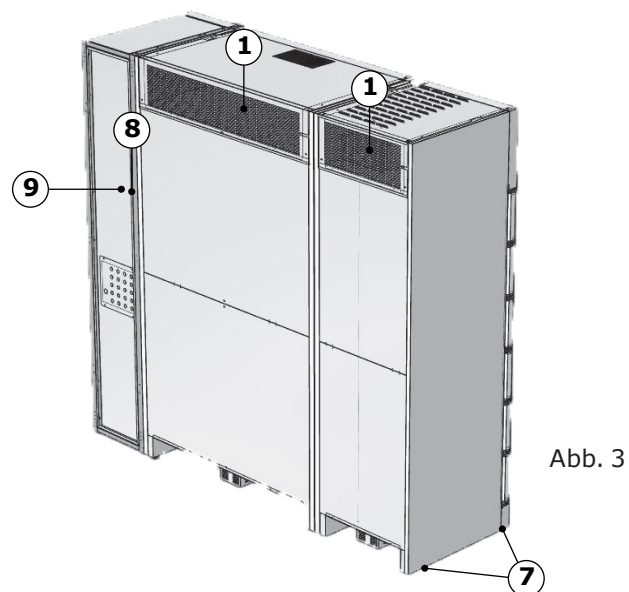
EPTABRICKS OUTDOOR TN-AMBIENT 6 DOORS

EPTABRICKS OUTDOOR BT 5 DOORS



Abb. 4



Abb. 6

EPTABRICKS OUTDOOR TN-AMBIENT 8 DOORS

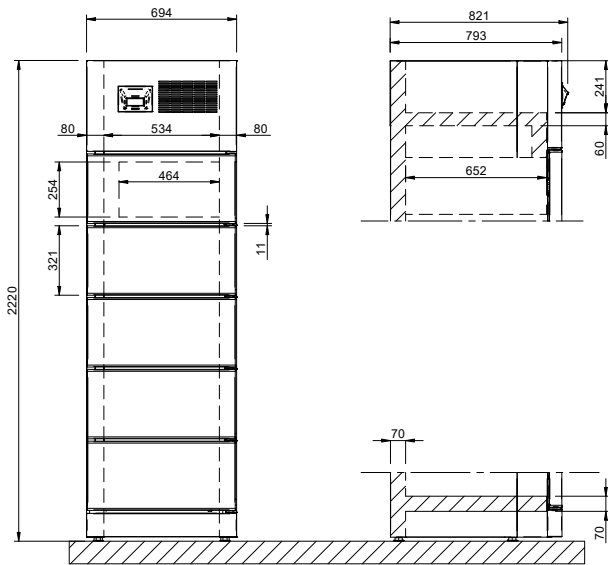
EPTABRICKS OUTDOOR BT 6 DOORS

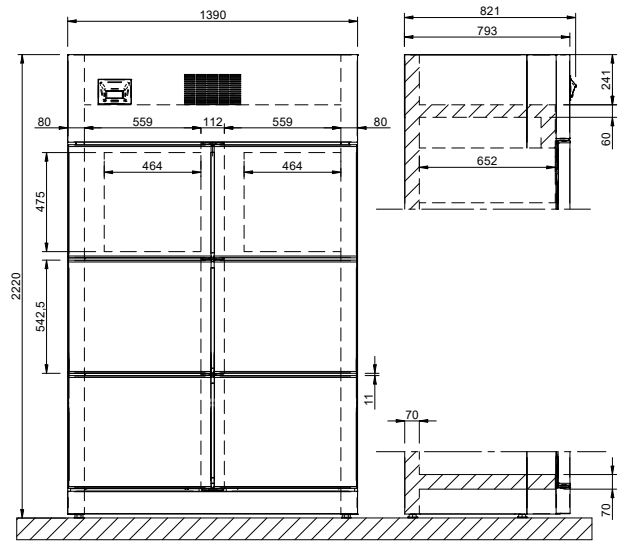

Abb. 5



Abb. 7

Modello - Modèle - Model Modell - Modelo - Modelo	EPTABRICKS 2.0 OUTDOOR	
Fabbricante - Constructeur - Manufacturer Hersteller - Fabricante - Fabricante	Epta Spa - Via Mecenate, 86 - 20138 Milano (MI) ITALIA Tel. 02/55403211 Telefax 02/55401023	8/27

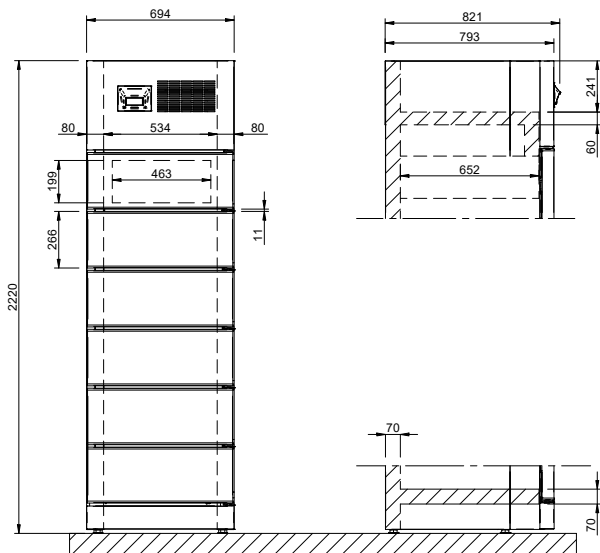
User manual

IT

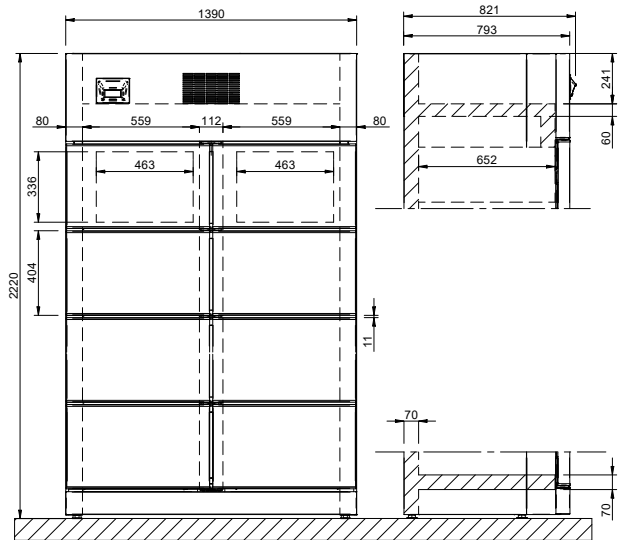
FR

EN

DE

ES

PT

EPTABRICKS OUTDOOR TN-AMBIENT 10 DOORS EPTABRICKS OUTDOOR DRY 8 DOORS



Abb. 8



Abb. 10

EPTABRICKS OUTDOOR DRY 6 DOORS

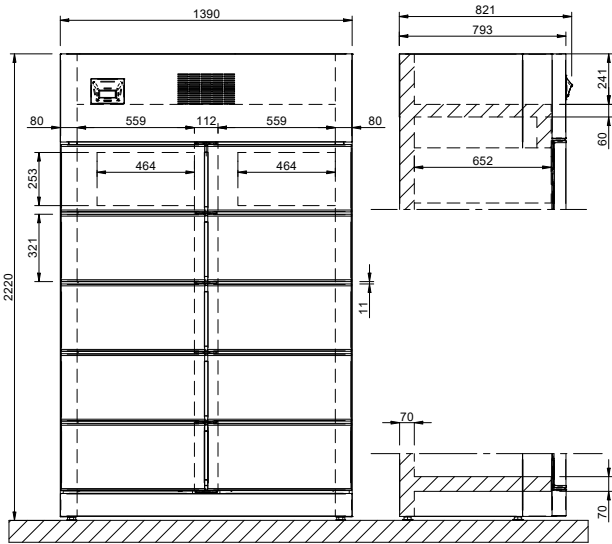

Abb. 9

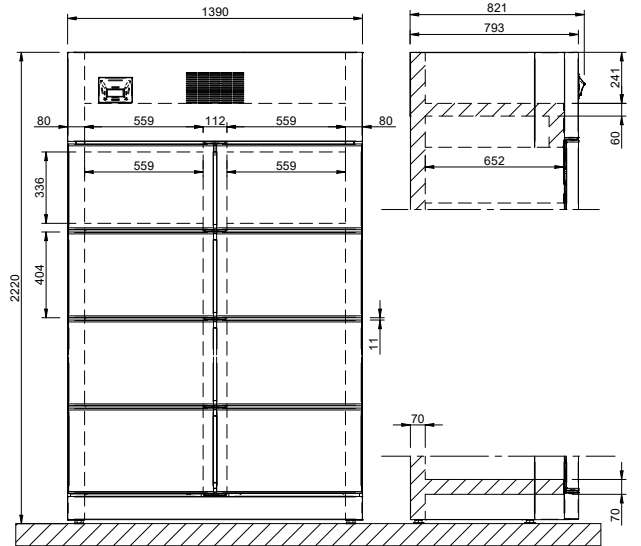
EPTABRICKS OUTDOOR DRY 10 DOORS

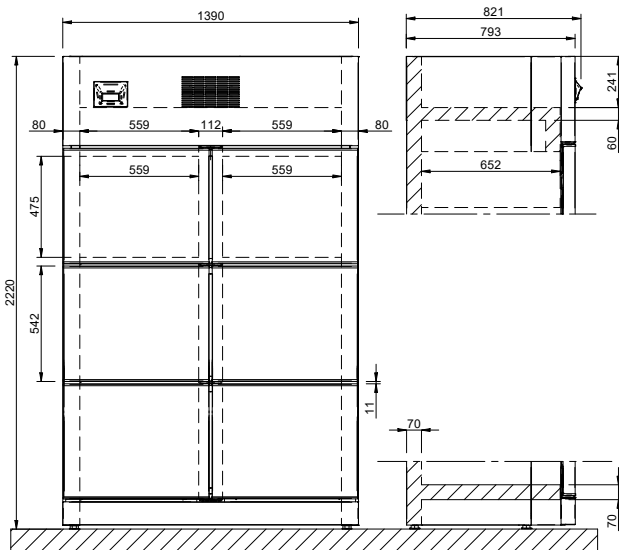

Abb. 11

Modello - Modèle - Model Modell - Modelo - Modelo	EPTABRICKS 2.0 OUTDOOR	
Fabbricante - Constructeur - Manufacturer Hersteller - Fabricante - Fabricante	Epta Spa - Via Mecenate, 86 - 20138 Milano (MI) ITALIA Tel. 02/55403211 Telefax 02/55401023	9/27

EPTABRICKS OUTDOOR MASTER

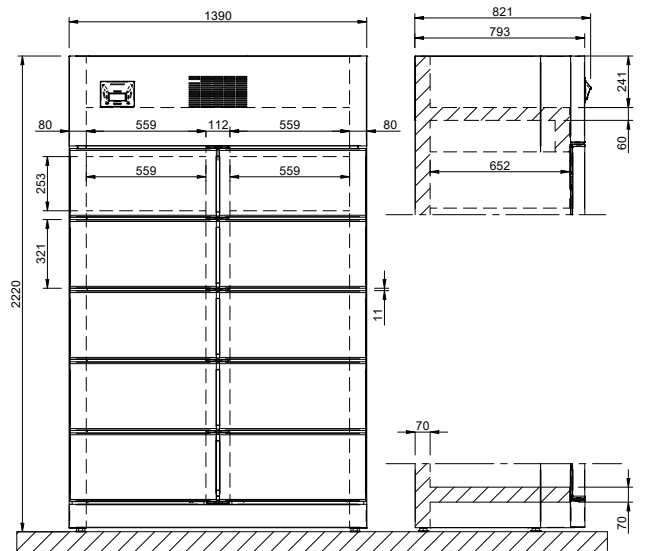

Abb. 12

IT

FR

EN

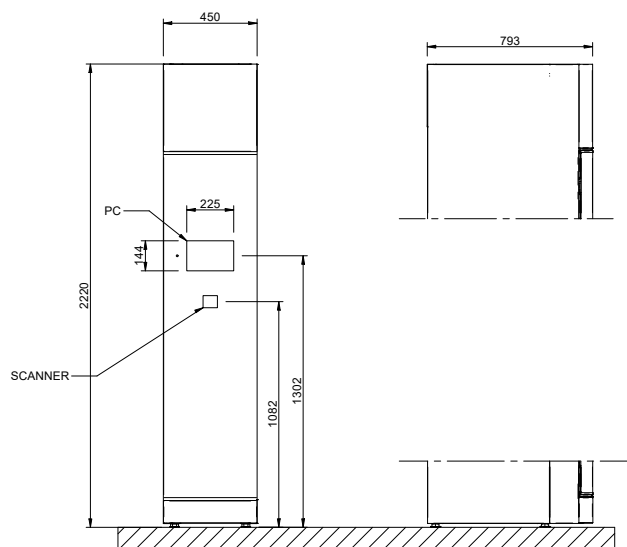
DE

ES

PT

Modello - Modèle - Model Modell - Modelo - Modelo	EPTABRICKS 2.0 OUTDOOR	 Epta
Fabbricante - Constructeur - Manufacturer Hersteller - Fabricante - Fabricante	Epta Spa - Via Mecenate, 86 - 20138 Milano (MI) ITALIA Tel. 02/55403211 Telefax 02/55401023	10/27

User manual

4. TRANSPORT DES KÜHLMÖBELS



Abb. 13



Abb. 14

1. Hebepunkte

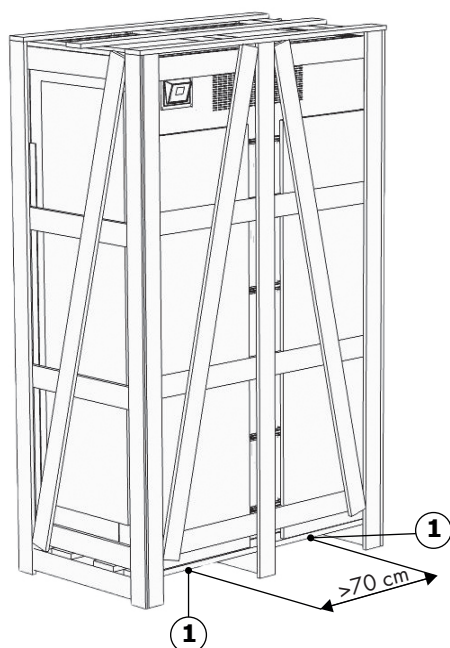
Tab. I

Modell	Gewicht (kg)	Gewicht mit Verpackung (kg)
EPTABRICKS OUTDOOR BT 5 DOORS	140	150
EPTABRICKS OUTDOOR BT 6 DOORS	140	150
EPTABRICKS OUTDOOR TN-AMBIENT 6 DOORS	250	263
EPTABRICKS OUTDOOR TN-AMBIENT 8 DOORS	250	263
EPTABRICKS OUTDOOR TN-AMBIENT 10 DOORS	250	263
EPTABRICKS OUTDOOR DRY 6 DOORS	135	145
EPTABRICKS OUTDOOR DRY 8 DOORS	135	145
EPTABRICKS OUTDOOR DRY 10 DOORS	135	145
EPTABRICKS OUTDOOR MASTER	90	100

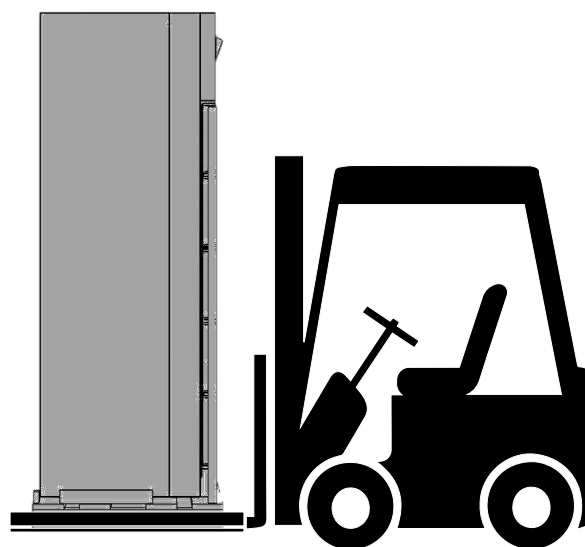
Modello - Modèle - Model Modell - Modelo - Modelo	EPTABRICKS 2.0 OUTDOOR	 Epta
Fabbricante - Constructeur - Manufacturer Hersteller - Fabricante - Fabricante	Epta Spa - Via Mecenate, 86 - 20138 Milano (MI) ITALIA Tel. 02/55403211 Telefax 02/55401023	11/27

5. UMGEBUNGSBEDINGUNGEN

- IT
- FR
- EN
- DE**
- ES
- PT



Abb. 15



Abb. 17

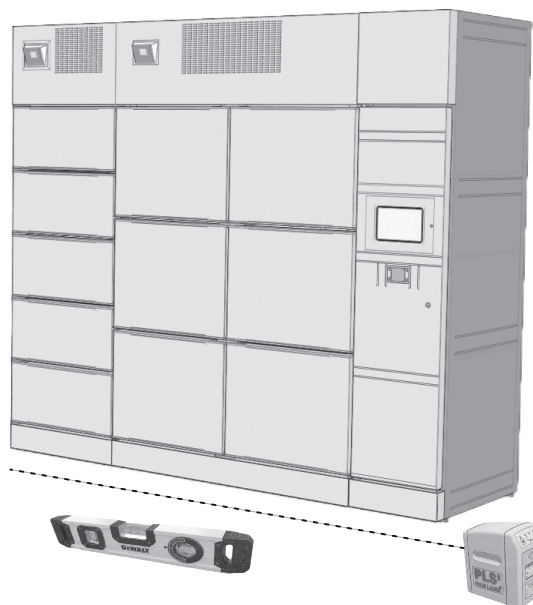

Abb. 16

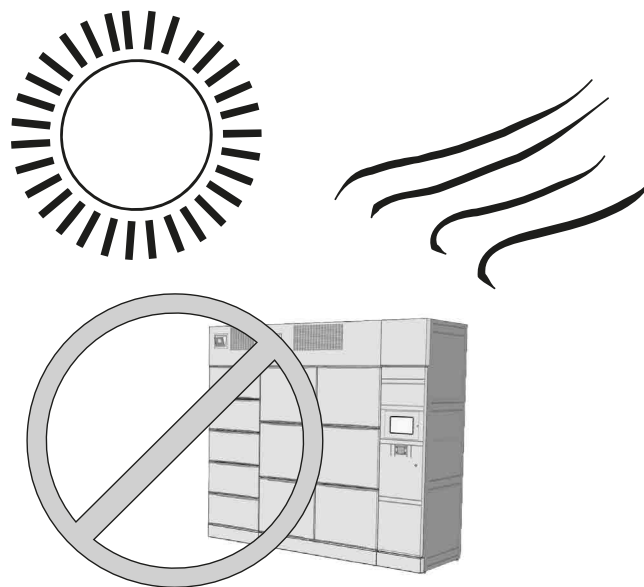

Abb. 18

Modello - Modèle - Model Modell - Modelo - Modelo	EPTABRICKS 2.0 OUTDOOR	 Epta
Fabbricante - Constructeur - Manufacturer Hersteller - Fabricante - Fabricante	Epta Spa - Via Mecenate, 86 - 20138 Milano (MI) ITALIA Tel. 02/55403211 Telefax 02/55401023	12/27

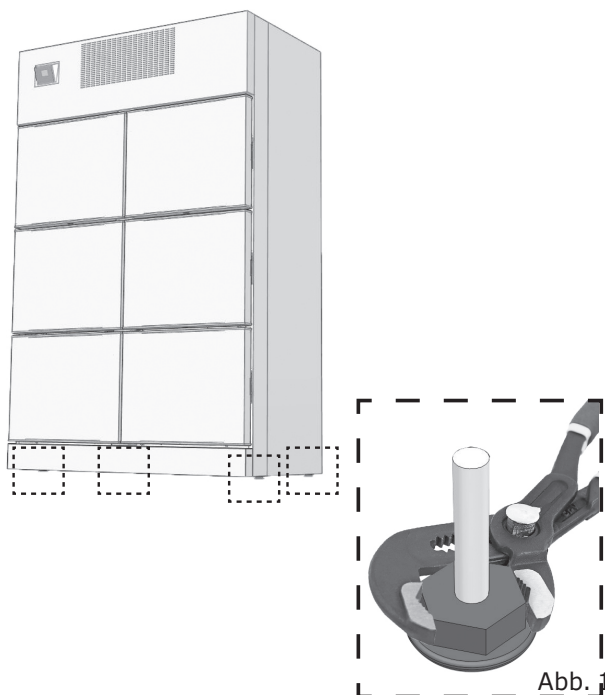
User manual

6. UMGEBUNGSBEDINGUNGEN

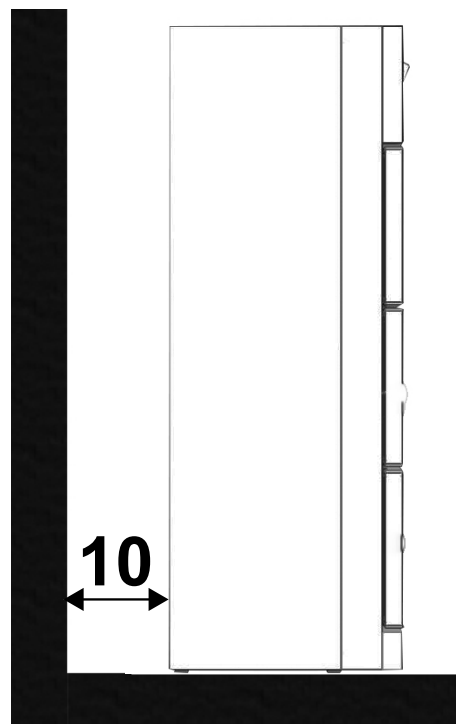

Abb. 19



Abb. 20

Tab. II

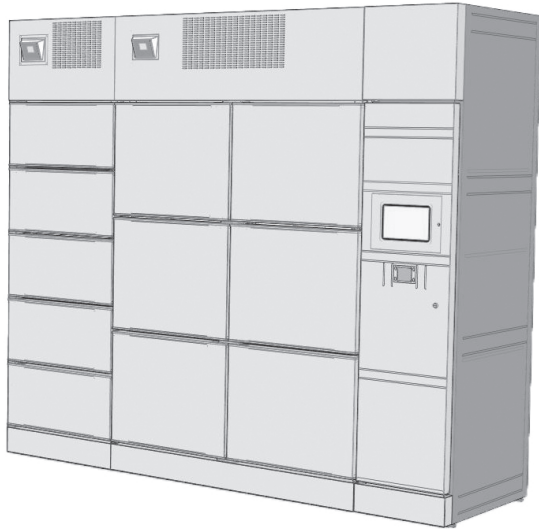
Umgebungsbedingungen	
Art	Max value
Temperatur	35°C
Relative Luftfeuchtigkeit	75 %

Modello - Modèle - Model Modell - Modelo - Modelo	EPTABRICKS 2.0 OUTDOOR	
Fabbricante - Constructeur - Manufacturer Hersteller - Fabricante - Fabricante	Epta Spa - Via Mecenate, 86 - 20138 Milano (MI) ITALIA Tel. 02/55403211 Telefax 02/55401023	13/27

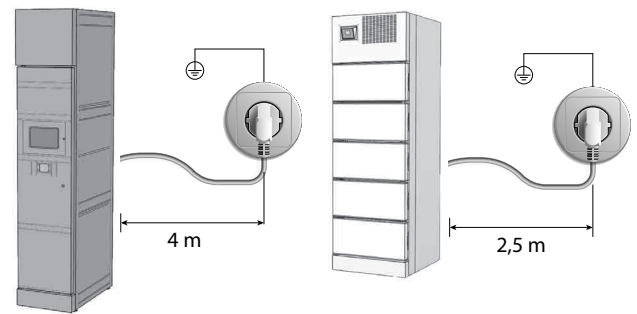
7. TECHNISCHE EIGENSCHAFTEN







 <small>EPTA S.p.A. Via Mecenate, 86 20138 Milano - Italy</small>		12	
1 2		SN 13	 14
REF 15		16	
RATED BEMESSUNG ASSIGNÉ NOMINALE NOMINAL	3 4 5 6	REFRIGERANT KÄLTEMITTEL RÉFRIGÉRANT REFRIGÉRANTE REFRIGERANTE	17 18 19 20
DEFROSTING ABTAUUNG DÉGIVRAGE SBRINAMENTO DESCONGELAMIENTO	7 8	CLIMATIC CLASS KLIMAKLASSE CLASSE CLIMATIQUE CLASSE CLIMATICA CLASE CLIMÁTICA	21
HEATING SYSTEMS HEIZUNGSSYSTEME SYSTEMES CHAUFFANTS SISTEMI DI RISCALDAMENTO SISTEMA DE CALEFACCIÓN	9	INSULATION BLOWING GAS ISOLATIONS GAS (BLÄHGAS) AGENT MOUSSANT D'ISOLATION GAS ESPUMANTE ISOLAMENTO AGENTE ESPUMANTE	22
	10	PROTECTION INDEX SCHUTZART INDEX DE LA PROTECTION INDICE DI PROTEZIONE ÍNDICE DE PROTECCIÓN	23
	Read Operator's Manual available at www.eptarefrigeration.com or calling +39 0437 968379	24	 25 

Abb. 21

- | | |
|--------------------------------------|---------------------------------------|
| 1. Produktherkunft | 14. Herstellungsdatum |
| 2. Hergestellt in "Herstellungsland" | 15. Hat Code |
| 3. Nennspannung | 16. Modell |
| 4. Nennleistung | 17. Kältemittelart 1 |
| 5. Nennfrequenz | 18. Kältemittelmasse 1 |
| 6. Nennstrom | 19. Kältemittelart 2 |
| 7. Abtauleistung | 20. Kältemittelmasse 2 |
| 8. Strom für die Abtauautomatik | 21. Klimaklasse |
| 9. Heizsystem | 22. Isolierung der Kältemittelleitung |
| 10. Beleuchtungssystem | 23. Schutzklasse |
| 11. Betriebshandbuch | 24. Zertifizierungskennzeichen |
| 12. Barcode | 25. WEEE-Kennzeichnung |
| 13. Seriennummer | |



Achtung: Enthält entzündliches Kältegas.

Tab. III

Menge des Kältemittels R290 (g)	
Modell	Menge (g)
EPTABRICKS OUTDOOR BT	-
EPTABRICKS OUTDOOR TN	-
EPTABRICKS OUTDOOR AMBIENT	-

Modello - Modèle - Model Modell - Modelo - Modelo	EPTABRICKS 2.0 OUTDOOR	 Epta
Fabbricante - Constructeur - Manufacturer Hersteller - Fabricante - Fabricante	Epta Spa - Via Mecenate, 86 - 20138 Milano (MI) ITALIA Tel. 02/55403211 Telefax 02/55401023	14/27

User manual

8. VERWENDUNG DES KÜHLMÖBELS

IT
FR
EN
DE
ES
PT



Abb. 22



Abb. 24

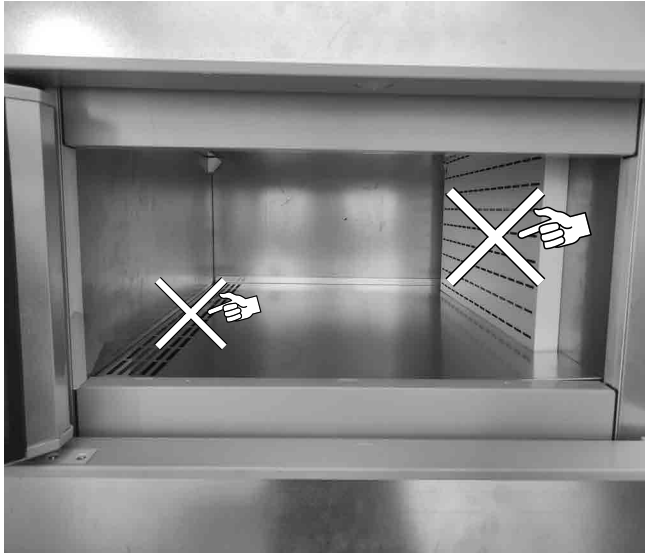

Nicht zudecken

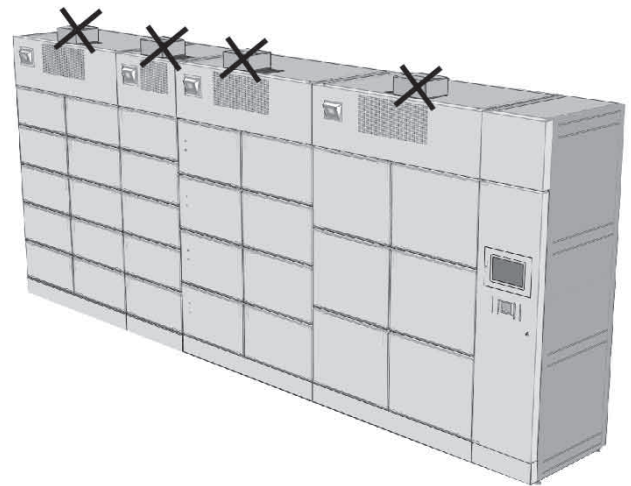

Abb. 23



Abb. 25

Modello - Modèle - Model Modell - Modelo - Modelo	EPTABRICKS 2.0 OUTDOOR	 Epta
Fabbricante - Constructeur - Manufacturer Hersteller - Fabricante - Fabricante	Epta Spa - Via Mecenate, 86 - 20138 Milano (MI) ITALIA Tel. 02/55403211 Telefax 02/55401023	15/27

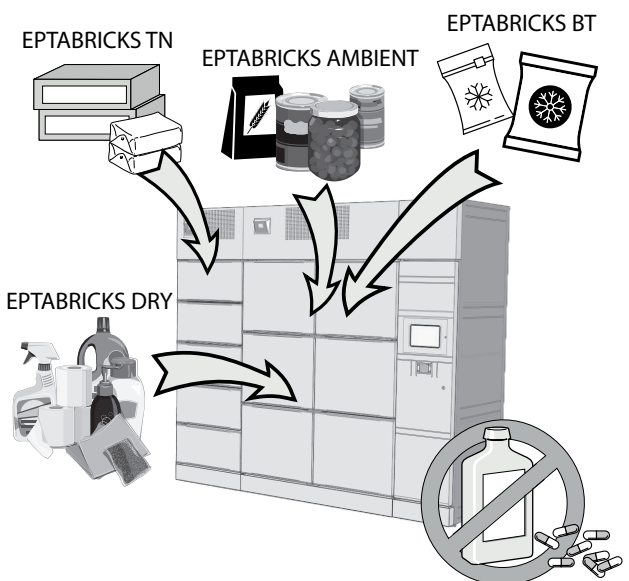
- IT
- FR
- EN
- DE**
- ES
- PT

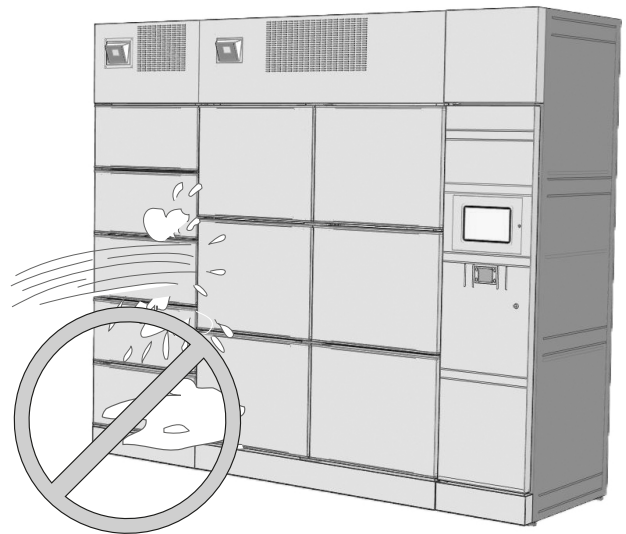

Abb. 26



Abb. 28



Abb. 27

Modello - Modèle - Model Modell - Modelo - Modelo	EPTABRICKS 2.0 OUTDOOR	 Epta
Fabbricante - Constructeur - Manufacturer Hersteller - Fabricante - Fabricante	Epta Spa - Via Mecenate, 86 - 20138 Milano (MI) ITALIA Tel. 02/55403211 Telefax 02/55401023	16/27

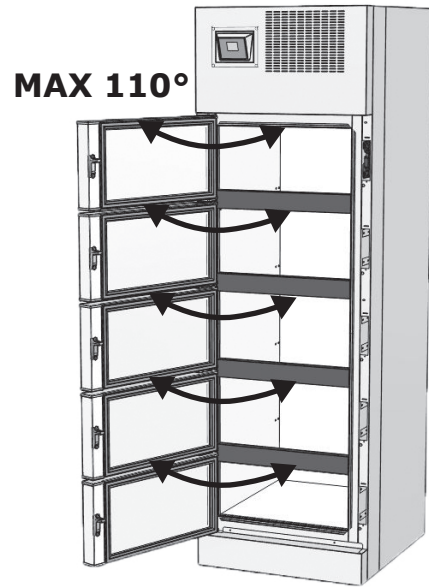
9. WARTUNG DES MÖBELS

9.1 Die Reinigung des Kühlmöbels

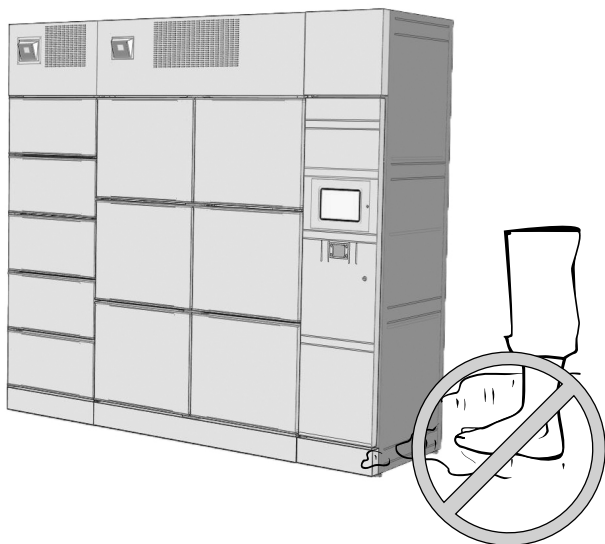
9.2 Reinigung wasserspeicherwanne



Abb. 29



Abb. 31

- Lösen Sie und entfernen Sie die Unterabdeckung und die Abdeckung der Wanne.

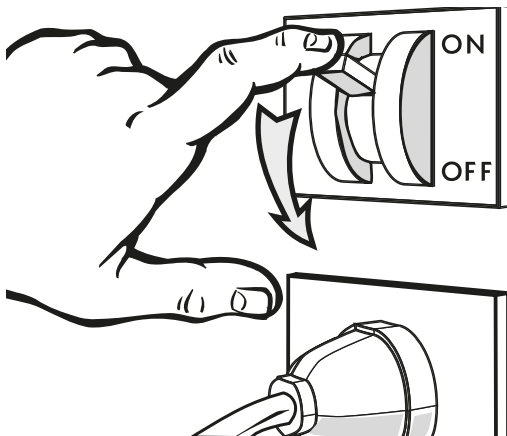
- Extrahieren Sie und säubern Sie die Wanne.

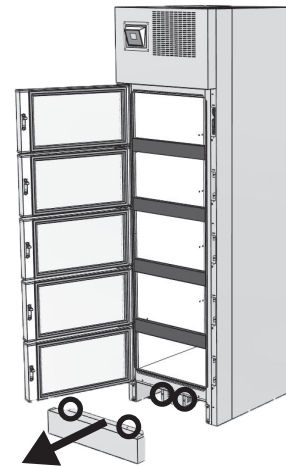

Abb. 30



Abb. 32



Reinigung abhängig von Verwendung und Notwendigkeit sowie unter besonderen Umgebungsbedingungen (z.B. hohe Luftfeuchtigkeit, niedrige Umgebungstemperatur, Vorhandensein von Staub usw.), um eine falsche und unvollständige Verdunstung von Wasser und/oder das Auftreten unangenehmer Gerüche zu vermeiden.

Modello - Modèle - Model Modell - Modelo - Modelo	EPTABRICKS 2.0 OUTDOOR	
Fabbricante - Constructeur - Manufacturer Hersteller - Fabricante - Fabricante	Epta Spa - Via Mecenate, 86 - 20138 Milano (MI) ITALIA Tel. 02/55403211 Telefax 02/55401023	17/27

10. HINWEISE FÜR DEN NUTZER

10.1 Beschreibung des Kühlmöbels

Das Eptabricks TN Kühlmöbel wurde so geplant und hergestellt, daß es für die Aufbewahrung von frischen, verpackten Lebensmitteln, Getränken und Milchprodukten geeignet ist.

Das Gerät EptaBricks BT darf ausschließlich für den Verkauf von tiefgefrorenen Waren verwendet werden.

Das Gerät EptaBricks AMBIENT darf ausschließlich für den Verkauf von Produkten, welche zur Aufbewahrung keiner Kühlung bedürfen, verwendet werden.

Das Gerät EptaBricks DRY darf ausschließlich für den Verkauf von Produkten NO FOOD.

TEMPERATURKLASSE EPTABRICKS 2.0
OUTDOOR TN (EN-ISO 23953-2): 7M2.

TEMPERATURKLASSE EPTABRICKS 2.0
OUTDOOR BT (EN-ISO 23953-2): 7L1.

TEMPERATURKLASSE EPTABRICKS 2.0
OUTDOOR AMBIENT (EN-ISO 23953-2): 7S.

Beachten Sie, dass bei Transport, Handling, Anlieferung, Lagerung, Aufstellung, Beladung, Benutzung, Reinigung und Wartung sowie bei der Demontage die Gefahr besteht, dass das Gerät umkippt ("Abb. 33").

Die allgemeinen Eigenschaften und die Abmessungen sind in den Abbildungen und in den Abschnitten der aufgeführt: "Allgemeine Beschreibung" (bis S. "7").



Abb. 33

10.2 Transport und Bewegung des Kühlmöbels

Das Möbel befindet sich in einer speziellen Verpackung mit einem Transportsockel für den Gabelstapler.

Verwenden Sie für die Bewegung des Möbels:

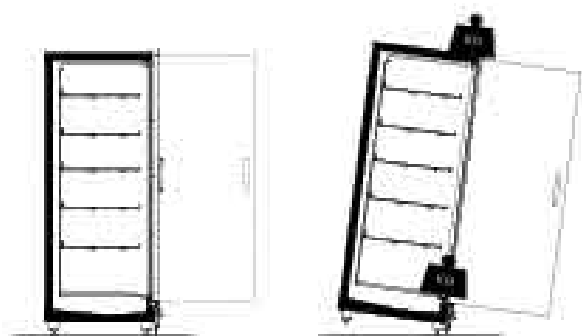
- Ausschließlich einen speziell geeigneten oder gleichwertigen Transportsockel
- Einen manuellen oder elektrischen Hubwagen, der für das Anheben des Möbels geeignet ist und über die vorgeschriebenen Eigenschaften verfügt

Das Gerätegewicht (Leergewicht und mit Verpackung) und die Abmessungen der Verpackung sind im Abschnitt aufgeführt: "Transport des Kühlmöbels" (Tabelle "Tab. I" und Abb. auf S. "11").

Die Durchführung der Positionierungsarbeiten muss durch qualifiziertes Personal erfolgen. Dieses muss in der Lage sein, das Gewicht, die Hebepunkte und die für die Sicherheit und Tragfähigkeit am besten geeigneten Hilfsmittel richtig einzuschätzen.

10.3 Empfang und Lagerung des Möbels

Überprüfen Sie den Zustand der Verpackung, bevor Sie das Gerät in Empfang nehmen. Sollte die Verpackung sichtbare Beschädigungen aufweisen:

- Entfernen Sie die Verpackung unter den Augen des Lieferanten.
- Quittieren Sie den Empfang des Dokuments unter Vorbehalt

Der Hersteller haftet nicht für Schäden, die durch den Transport oder die unsachgemäße Lagerung des Kühlmöbels entstehen.

Das Gerät muss an einem Ort gelagert werden, der vor Sonneneinstrahlung und Witterungseinflüssen geschützt ist und in dem eine Temperatur zwischen -25°C und $+55^{\circ}\text{C}$ sowie eine Luftfeuchtigkeit zwischen 30% und 95% herrschen.

Modello - Modèle - Model Modell - Modelo - Modelo	EPTABRICKS 2.0 OUTDOOR	 Epta
Fabbricante - Constructeur - Manufacturer Hersteller - Fabricante - Fabricante	Epta Spa - Via Mecenate, 86 - 20138 Milano (MI) ITALIA Tel. 02/55403211 Telefax 02/55401023	18/27

10.4 Installation und Umgebungsbedingungen

Das Gerät ist nicht für die Installation im Freien geeignet.

Für den korrekten Betrieb müssen bei der Positionierung des Geräts folgende Voraussetzungen erfüllt sein:

- Das Gerät muss auf einem ebenen Untergrund aufgestellt werden. ("Abb. 15").
- Das Gerät hat verstellbare Füße, um es aufzuhalten und aufzustellen ("Abb. 16"). Das Gerät muss, sobald es aufgestellt worden ist, auf dem Boden stabilisiert werden.
- Es ist wichtig, dass die Kompressoreinheit, die sich im oberen Teil der Säule befindet, immer von einem Schutzdach abgedeckt wird. Nicht direkt dem Regen und dem schlechten Wetter aussetzen ("Abb. 17").
- Die angegebenen Abstände "Abb. 18" (cm) für die korrekte Installation des Geräts müssen unbedingt eingehalten werden.

Es muss genug Platz vorhanden sein, damit die Kundschaft das Gerät bedienen kann.

Die Hinweise zu den Umgebungsbedingungen, in denen das Gerät aufgestellt werden soll, finden Sie in "Umgebungsbedingungen".

10.5 Elektrischer Anschluss



Wurde das Kühlregal zum Zweck der Einbringung oder der Montage von Zubehör stark geneigt, so muß das Kühlregal vor der Inbetriebnahme mindestens drei Stunden ruhen. Hierdurch kann sich das Schmieröl im Verdichter sammeln. Wird dies nicht beachtet, kann es zu einem Totalschaden der Verdichter-Kältemaschine kommen.



DER STROMKREIS, MIT DEM DAS KÜHLGERÄT VERBUNDEN WIRD, MUSS MIT EINEM HOCHEMPFLINDLICHEN FEHLERSTROMSCHUTZSCHALTER (In=16 A, Id = 30 mA) ABGESICHERT UND MIT DER ERDUNGSANLAGE VERBUNDEN SEIN. Die Erdung ist für ein korrektes Funktionieren des Geräts notwendig und obligatorisch.

Dem Gerät muss ein allpoliger Trennschalter vorgeschaltet werden. Dieser muss:

- einen Mindestabstand der Kontakte von 3 mm aufweisen
- Über eine ausreichende Trennungsstärke verfügen

Das Kabel ist ordentlich, vor Stößen geschützt und weder in der Nähe von Flüssigkeiten oder Wasser, noch von Wärmequellen zu verlegen.

Der Trennschalter muss so montiert werden, dass er im Falle einer auftretenden Gefahrensituation einfach betätigt werden kann (Entfernung maximal 3 m).

Vergewissern Sie sich, dass die Netzspannung mit den Angaben auf dem Typenschild übereinstimmt, bevor Sie das Möbel an den Strom anschließen. Damit der ordnungsgemäße Betrieb gewährleistet ist, darf die Spannung insgesamt maximal zwischen +/- 6% vom Nennwert abweichen.

10.6 Technische eigenschaften

Auf dem Typenschild werden alle spezifischen technischen Gerätedaten angegeben. Sie finden seine Position und die Art der Angaben in "Technische eigenschaften" ("Abb. 21").

Sie finden die Schaltpläne, Kalibrierungslisten der Kontrollinstrumente, Installationsanweisungen sowie eine Kopie der Konformitätserklärung unter dem folgenden Link: <https://documents.eptarefrigeration.com>. Der durch den Betrieb des Geräts erzeugte Schalldruckpegel liegt unter 70 dB(A). Das Möbel erzeugt keine schädlichen Schwingungen.

Modello - Modèle - Model Modell - Modelo - Modelo	EPTABRICKS 2.0 OUTDOOR	 Epta
Fabbricante - Constructeur - Manufacturer Hersteller - Fabricante - Fabricante	Epta Spa - Via Mecenate, 86 - 20138 Milano (MI) ITALIA Tel. 02/55403211 Telefax 02/55401023	19/27

10.7 Die Befüllung des Kühlmöbels

Schalten Sie das Gerät über den an der Wand montierten Hauptschalter ein, um den Kühlkreislauf zu starten. Etwa 2 später können Sie damit beginnen, das Kühlmöbel zu befüllen. Das Gerät ist dafür ausgelegt, die Temperatur der enthaltenen Waren aufrechtzuerhalten. Es ist nicht dazu ausgelegt, die Warentemperatur zu senken. Es sollten daher nur Waren in das Kühlmöbel gelegt werden, die bereits auf ihre jeweilige Lagertemperatur heruntergekühlt wurden. Sie sollten niemals Produkte im Kühlmöbel lagern, die sich zuvor erwärmt haben. Achten Sie beim Befüllen des Kühlmöbels darauf, dass:

- Das Kühlmöbel unter Berücksichtigung der Größe und Art der Waren gleichmäßig befüllt wird
- Die Waren nicht die Zirkulation der Kaltluft beeinträchtigen ("Abb. 22")
- Für eine gute Konservierung des Produktes, einen Abstand von etwa 10 cm vom oberen Teil des Türfachs halten.



Maximaler Türöffnungswinkel = 110°. Um Schäden an den Türen zu vermeiden und/oder Funktionsstörungen hervorzurufen, die Türen nicht weiter als 110° öffnen.

Das zulässige Gesamtgewicht sich gleichmäßig im Kühlmöbel verteilt: 32 Kg .

10.8 Zugang

Informationen zugang

Das Modell EptaBricks verfügt an jeder Annahmestelle über eine von EPTA installierte Software.

In diesem Handbuch wird der Zugang zur Software für folgende Profile beschrieben:

- Profil kunde
- Profil zusteller

Jedes Profil verfügt über andere Zugangskriterien und daher auch über ein anderes Menü.

ACHTUNG! Das Türschloss ist ausgestattet mit einem magnetischen Anschlag; bei offener Tür wird das Öffnen mit einem Alarm signalisiert.

Profil kunde - Produkt entgegennehmen

Die Kolonne MASTER ermöglicht die Entgegennahme von Bestellungen, sowohl durch Einscannen / Eingabe der Bestellnummer, als auch mittels Einscannen / Eingabe der Kundenkarte.

Wird eine Kundenkarte verwendet und der Kunde hat mehrere Bestellungen offen, öffnet sich am Bildschirm eine Liste mit den Bestellungen, welche entgegen genommen werden können.

Die Türen öffnen sich, eine nach der anderen; um eine Tür öffnen zu können, muss die vorhergehende geschlossen werden.

Hat der Kunde die Waren entgegen genommen, stehen ihm folgende Möglichkeiten zur Verfügung:

- Die Entgegennahme der Waren abschließen und zur Anfangsbildschirmanzeige zurück kehren.
- Nochmals die Türen zu öffnen (wenn er der Meinung ist etwas vergessen zu haben).

Im Falle von Störungen wird der Kunde durch eine Fehlermeldung darauf hingewiesen. Diese Bildschirmseite wird vom Geschäft individuell angepasst.

- Durch Drücken der zentralen weißen Taste werden die Produkte entgegen genommen.



#EPTABricks
24/7



Abb. 34

Modello - Modèle - Model Modell - Modelo - Modelo	EPTABRICKS 2.0 OUTDOOR	
Fabbricante - Constructeur - Manufacturer Hersteller - Fabricante - Fabricante	Epta Spa - Via Mecenate, 86 - 20138 Milano (MI) ITALIA Tel. 02/55403211 Telefax 02/55401023	20/27

User manual

IT
FR
EN
DE
ES
PT

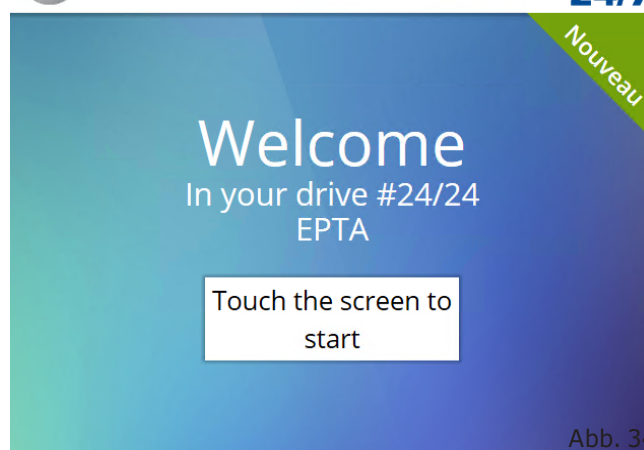
- Die Bestellnummer rechts oben am Bildschirm eingeben oder QR Code einscannen.

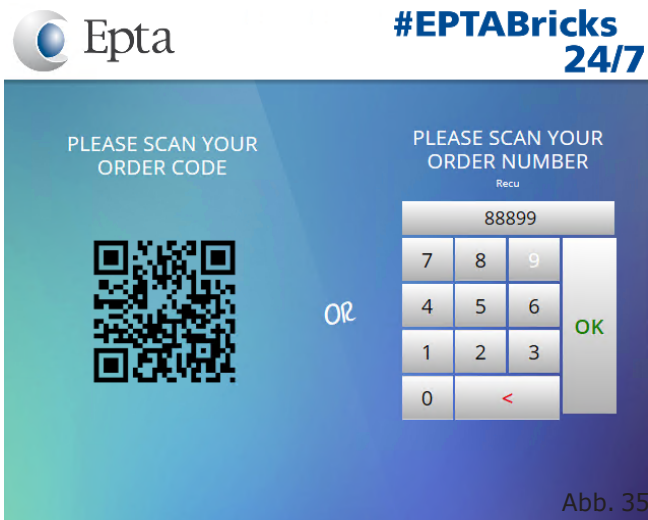

- Drücken, wenn die Ware entgegen genommen wurde, oder wenn noch einmal das Fach kontrolliert werden soll.



- Die Ware aus dem am Display in der Kolonne MASTER signalisierten Fach entnehmen. Wenn Sie die Ware entnommen haben, schließen Sie bitte die Tür wieder.

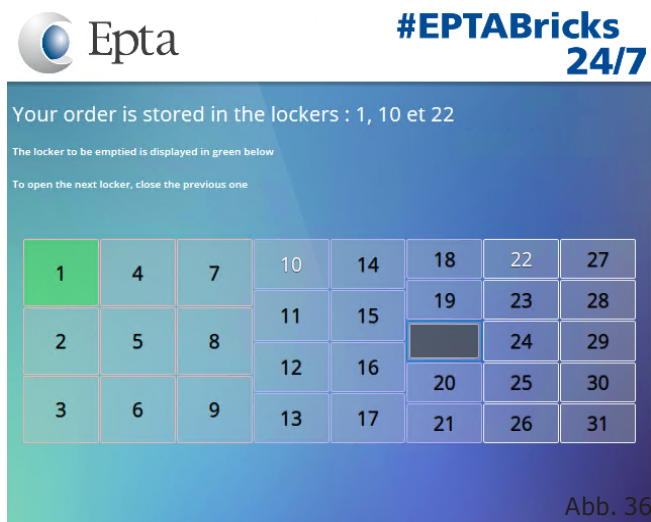

Profil zusteller - Produkt laden

Die Erstellung, Aktivierung und Deaktivierung von Konten erfolgt direkt im Erfassungsterminal. Jeder Zusteller verfügt über eine Identifikationsnummer, mit welcher er Daten einscannen oder Zugriff zum Terminal erlangen kann.

Der Zusteller kann sehen, wie viele Schalter frei sind. Er kann auch die Anwesenheit des Alarms sehen und die Liefermodalität wählen:

- Auto-Allocation: Die erste Tür öffnet sich automatisch und die nächste Tür wird nach der Schließung sich öffnen.
- No Auto-Allocation: Der Zusteller wählt aus, welche Tür er öffnen möchte, indem er darauf klickt.

Modello - Modèle - Model Modell - Modelo - Modelo	EPTABRICKS 2.0 OUTDOOR	 Epta
Fabbricante - Constructeur - Manufacturer Hersteller - Fabricante - Fabricante	Epta Spa - Via Mecenate, 86 - 20138 Milano (MI) ITALIA Tel. 02/55403211 Telefax 02/55401023	21/27

- Durch Drücken der zentralen weißen Taste werden die Produkte laden genommen.



Abb. 38

- Sehen Sie die freien Türen, auswählen Sie die Liefermodalität und drücken Sie die Taste „Laden“.



Abb. 40

- EInscannen / eingeben der Identifikationsnummer des Personals

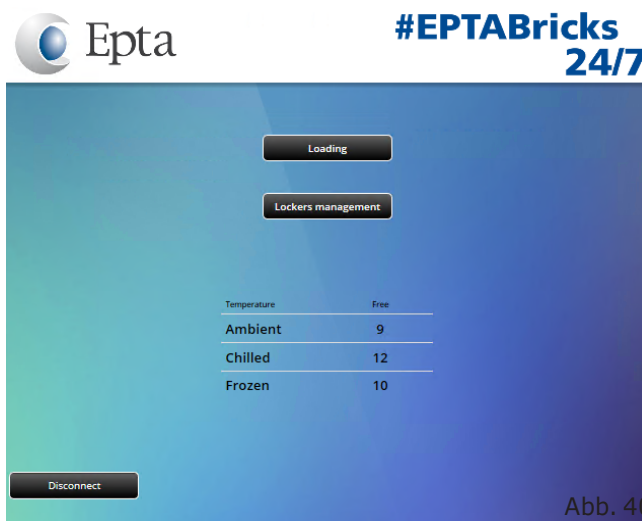

Abb. 39

- Bestellnummer eingeben und OK drücken.

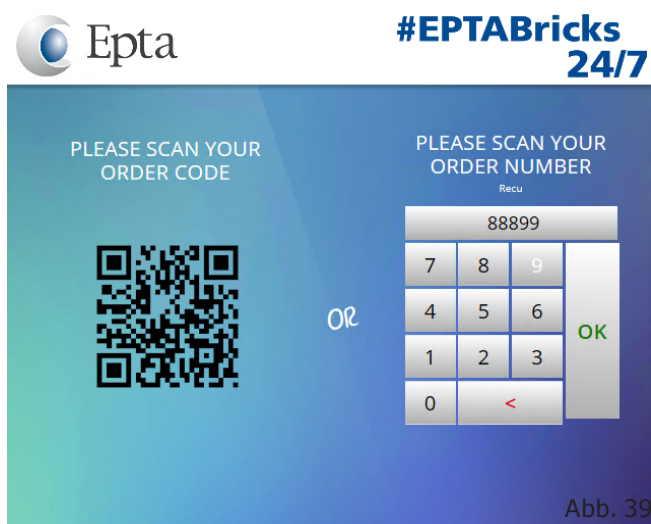

Modello - Modèle - Model Modell - Modelo - Modelo	EPTABRICKS 2.0 OUTDOOR	
Fabbricante - Constructeur - Manufacturer Hersteller - Fabricante - Fabricante	Epta Spa - Via Mecenate, 86 - 20138 Milano (MI) ITALIA Tel. 02/55403211 Telefax 02/55401023	22/27

User manual

- IT
- FR
- EN
- DE
- ES
- PT

- Es öffnet sich das zu ladende Fach. Ist das Fach geladen, Türe schließen.



Abb. 42

- Nachdem die Fächer der Bestellung geladen wurden, können mit der Taste unten rechts weitere Fächer zugefügt werden.

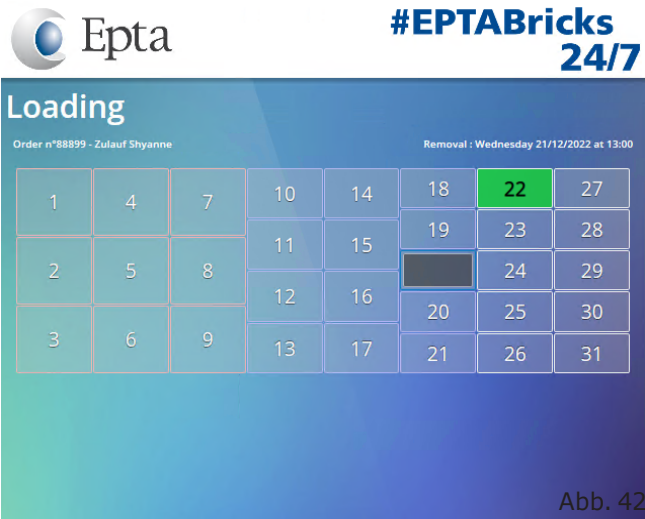

Abb. 44

- Wenn für die Bestellung mehrere Fächer geladen werden sollen (aus Mengen- oder Temperaturgründen), öffnet sich das Fach, wenn das vorhergehende geschlossen wurde.

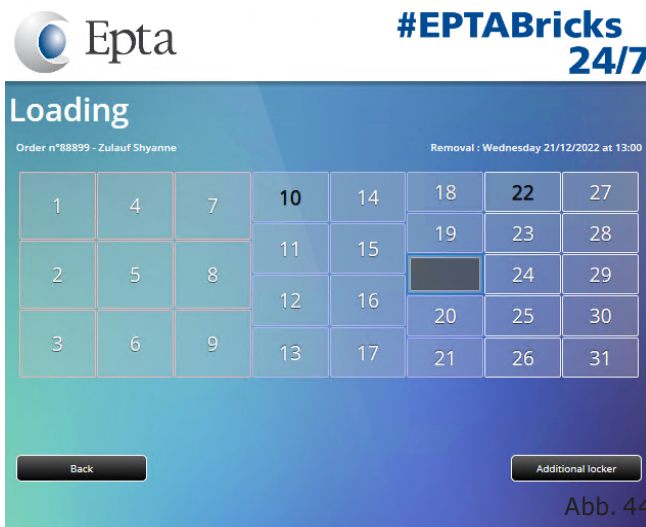

Abb. 43

- Den Typ des Faches, welches zugefügt werden soll, auswählen.

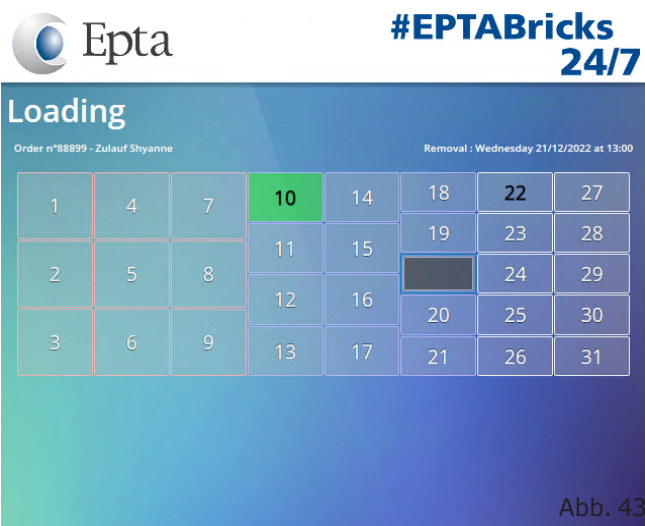

Abb. 45

Modello - Modèle - Model Modell - Modelo - Modelo	EPTABRICKS 2.0 OUTDOOR	
Fabbricante - Constructeur - Manufacturer Hersteller - Fabricante - Fabricante	Epta Spa - Via Mecenate, 86 - 20138 Milano (MI) ITALIA Tel. 02/55403211 Telefax 02/55401023	23/27

- Dieses wird aktiviert und öffnet sich. Ist das Fach geladen, Türe schließen.

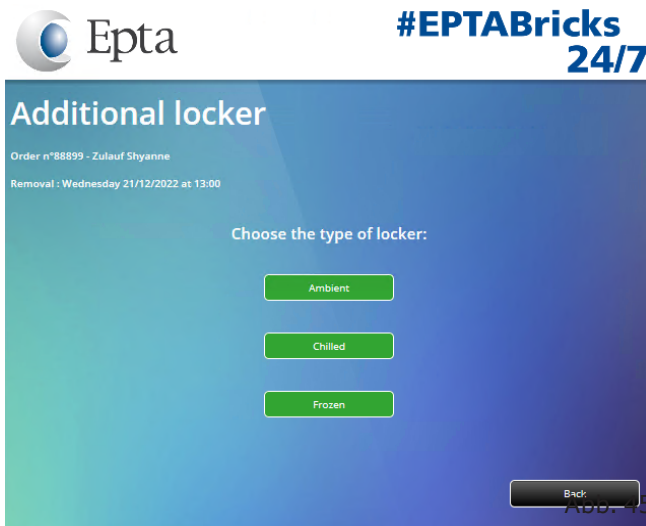

Abb. 46

- Sollen weitere Fächer zugefügt werden, die Taste unten rechts betätigen. Wurde hingegen die gesamte Ware der Bestellung geladen, die Taste unten links drücken.

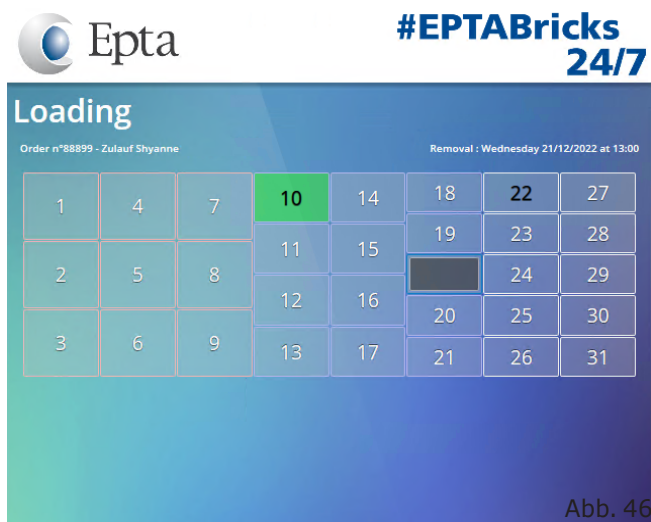

Abb. 47

10.9 Reinigung und regelmäßige Wartung

Es wird empfohlen, im Arbeitsbereich für gute Lichtverhältnisse zu sorgen und eventuell eine zusätzliche Leuchtquelle einzuschalten.

Die Reinigung des Kühlmöbels

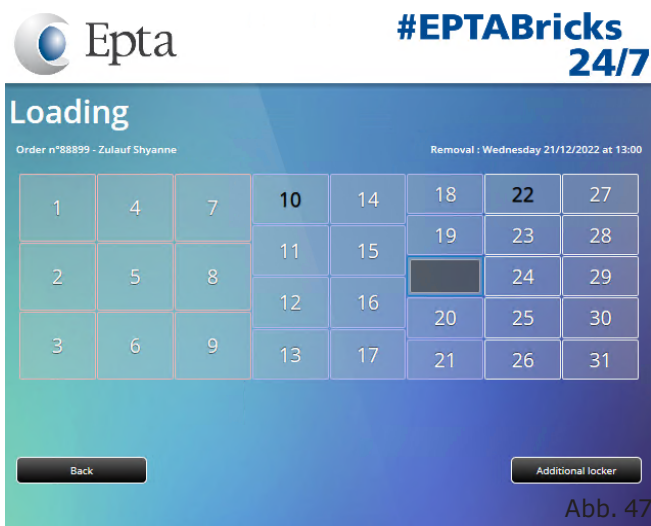
Verwenden Sie für die Reinigung nur Wasser mit einer Temperatur von max. 65°C sowie milde Haushaltsseife oder ein in Wasser verdünntes, neutrales Reinigungsmittel.

Verwenden Sie auf keinen Fall:

- Scheuerschwämme
- Entzündliche Produkte oder aggressive Mittel wie Alkohol, Azeton oder Lösungsmittel
- Reinigungsmittel, die nichtionische Tenside, Zitrone oder Essig (Essigsäure) enthalten



Waschen oder reinigen Sie den oberen Teil des Kühlmöbels nicht mit Wasser oder anderen Flüssigkeiten.

Reinigen Sie alle Außenflächen des Kühlmöbels **EINMAL PRO WOCHE**: wenn erforderlich vorsichtig mit einem, in einer Lösung von Wasser und neutralem Waschmittel getränkten weichen Tuch reinigen.

TOUCH SCREEN: Niemals Lösungsmittel zur Reinigung verwenden oder Wasser direkt auf den Bildschirm schütten. Ein weiches Baumwolltuch leicht anfeuchten und vorsichtig über den Bildschirm gleiten lassen. Bildschirm gut trocknen und mit einem Mikrofaser Tuch nachwischen.

Reinigen Sie alle Innenflächen des Kühlmöbels **EINMAL PRO MONAT** und befolgen Sie dafür die folgende Anleitung:

- Trennen Sie das Kühlmöbel mit Hilfe des Wandschalters vom Stromnetz ("Abb. 29").
- Entleeren Sie das Kühlmöbel und lagern Sie die Waren in Kühlzellen oder Kühlschränken, in denen die Konservierungstemperatur aufrechterhalten wird.
- Warten Sie ab, bis das Kühlmöbel die Umgebungstemperatur erreicht hat und fahren Sie mit der Reinigung folgendermaßen fort
- Stellen Sie sicher, dass der Innenraum des Kühlmöbels auch wirklich vollständig trocken ist und schließen Sie es dann wieder an die Stromversorgung an.
- Warten Sie ein paar Stunden ab, bevor Sie die Waren zurück in das Kühlmöbel legen.

Modello - Modèle - Model Modell - Modelo - Modelo	EPTABRICKS 2.0 OUTDOOR	 Epta
Fabbricante - Constructeur - Manufacturer Hersteller - Fabricante - Fabricante	Epta Spa - Via Mecenate, 86 - 20138 Milano (MI) ITALIA Tel. 02/55403211 Telefax 02/55401023	24/27

User manual

IT

Wenn Sie das Gerät außer Betrieb setzen, trennen Sie es von der Stromversorgung und verfahren wie oben beschrieben. Lassen Sie anschließend die Türen offen stehen (falls vorhanden), um zu vermeiden, dass sich unangenehme Gerüche bilden.

FR

EN

DE

ES

PT

Sie sollten das Kühlmöbel alle **DREI MONATE** abtauen, damit Eiskristalle, die sich möglicherweise auf den Lamellen des Verdampfers gebildet haben, schmelzen und seine Funktion nicht beeinträchtigen. Die Dauer und die Anzahl der Abtauvorgänge sind bereits werkseitig eingestellt. Änderungen dürfen nur durch den technischen Wartungsdienst vorgenommen werden. Das Abtauwasser fließt in einen speziellen Ablauf und sammelt sich in einer Verdunstungswanne am Boden des Kühlmöbels. Überprüfen Sie regelmäßig, dass das Abtauwasser normal abläuft.

Reinigung wasserspeicherwanne

Achtung! Je nach Verwendungsart und Bedarf und unter besonderen Umweltbedingungen (z.B. hohe Feuchtigkeit, niedrige Umgebungstemperaturen, Vorhandensein von Staub, usw.) reinigen, um die falsche und komplette Verdunstung des Wassers und/oder das Auftreten von unangenehmen Gerüchen zu vermeiden.

10.10 Gefahrensituationen

Das Gerät geht nicht an oder stellt seinen Betrieb ein:

- Stellen Sie sicher, ob nicht vielleicht ein allgemeiner Stromausfall die Ursache ist.
- Überprüfen Sie, ob der Hauptschalter an der Wand eingeschaltet ist.
- Kontrollieren Sie, ob der Netzstecker richtig eingesteckt ist.

Wenn keiner der vorgenannten Gründe die Ursache für die Stromunterbrechung ist, wenden Sie sich sofort an das nächstgelegene autorisierte Service-Center. Räumen Sie das Kühlmöbel schnellstmöglich leer und lagern Sie die Waren in Kühlzellen und Kühlschränken, in denen die korrekte Konservierungstemperatur herrscht.

Die Kühlleistung ist nicht ausreichend:

- Kontrollieren Sie zunächst, ob der Kondensator sauber ist und ein korrekter Wärmeaustausch stattfinden kann. Sollten die Lamellen verschmutzt sein, reinigen Sie sie sorgfältig.
- Stellen Sie sicher dass das Kühlmöbel korrekt befüllt wurde.
- Falls in den letzten drei Monaten nicht geschehen, tauen Sie das Kühlmöbel ab und lassen Sie es anschließend seinen normalen Betrieb wiederaufnehmen.
- Überprüfen Sie, ob sich in der Nähe des Kühlmöbels eine Wärmequelle oder ein Luftzug befindet.
- Kontrollieren Sie die Umgebungsbedingen, so wie sie im Abschnitt beschrieben sind: "Umgebungsbedingungen" ("Tab. II").
- Stellen Sie mit Hilfe einer Wasserwaage sicher, dass das Möbel gerade steht.
- Stellen Sie sicher, dass die Tür richtig schließt

Sollte die Kühlleistung noch immer nicht ausreichend sein, wenden Sie sich an das nächste autorisierte Service-Center.

Modello - Modèle - Model Modell - Modelo - Modelo	EPTABRICKS 2.0 OUTDOOR	 Epta
Fabbricante - Constructeur - Manufacturer Hersteller - Fabricante - Fabricante	Epta Spa - Via Mecenate, 86 - 20138 Milano (MI) ITALIA Tel. 02/55403211 Telefax 02/55401023	25/27

Das Kühlmöbel ist laut:

- Stellen Sie sicher, dass alle Schrauben und Muttern fest angezogen sind.
- Stellen Sie mit Hilfe einer Wasserwaage sicher, dass das Möbel gerade steht.

Sollte der Lärm andauern, wenden Sie sich an das nächste autorisierte Service-Center.

10.11 Technischer Wartungsdienst

Sollten Sie technische Hilfe benötigen, wenden Sie sich bitte umgehend an den Lieferanten, bei dem Sie das Gerät gekauft haben.

Sollten Sie Ersatzteile benötigen, wenden Sie sich immer an den technischen Kundendienst: Fragen Sie nach und vergewissern Sie sich, dass auch wirklich Originalersatzteile verwendet werden.

10.12 Demontage und Entsorgung

HINWEISE ZUR KORREKTEN ENTSORGUNG DES PRODUKTES GEMÄSS DER EUROPÄISCHEN RICHTLINIE 2012/19/EU

Aus Gründen des Umweltschutzes und in Übereinstimmung mit der EU-Richtlinie 2011/65/EU müssen Möbel für gekühlte und tiefgekühlte Produkte am Ende ihrer Betriebsdauer ordnungsgemäß entsorgt und recycelt werden.

Indem der Nutzer dies sicherstellt, leistet er einen wichtigen Beitrag, um möglichen Konsequenzen für Umwelt und Gesundheit vorzubeugen.

Möbel, die mit einem Kühlsystem ausgestattet und mit einem Netzstecker versehen (und somit einsatzbereit) sind, werden als WEEE definiert: "Waste Electrical and Electronic Equipment" (Elektro- und Elektronik-Altgeräte).

- Bringen Sie die Möbel in ein speziell darauf ausgerichtetes Recycling- und Verwertungszentrum für WEEE.
- Alternativ können Sie die Möbel auch zum Händler oder zum Hersteller bringen.
- In jedem Fall muss während des Transports und während des Be- und Entladens der Schutz der ausrangierten Elektro- und Elektronik-Altgeräte, die entsorgt oder verwertet werden sollen, gewährleistet sein. Lassen Sie die Geräte nie unbeaufsichtigt, auch nicht für wenige Tage.
- Vermeiden Sie die Beschädigung des Kühlkreislaufs: Die enthaltenen Kältemittel können eine umweltschädigende Wirkung haben, für sie gelten besondere Vorschriften.
- Stellen Sie sicher, dass alle Möbeltüren fest verschlossen sind und dass bewegliche Teile gut fixiert sind.
- Trennen Sie das Gerät vom Leitungsnetz und durchtrennen Sie das Netzkabel, um es unbrauchbar zu machen.

Das Symbol auf dem Typenschild und auf der beiliegenden Dokumentation weist darauf hin, dass:

Modello - Modèle - Model Modell - Modelo - Modelo	EPTABRICKS 2.0 OUTDOOR	 Epta
Fabbricante - Constructeur - Manufacturer Hersteller - Fabricante - Fabricante	Epta Spa - Via Mecenate, 86 - 20138 Milano (MI) ITALIA Tel. 02/55403211 Telefax 02/55401023	26/27

User manual

IT
FR
EN
DE
ES
PT



Abb. 48

- Das Produkt nach dem 13. August 2005 in den Verkehr gebracht wurde;
- Dieses Produkt "getrennt zu sammeln" ist, nicht wie Restmüll behandelt und nicht auf eine Deponie verbracht werden darf.

Für weitere Informationen über die Aufbereitung, Wiederverwertung und das Recycling dieses Produkts wenden Sie sich bitte an die zuständige örtliche Behörde, den örtlichen Abfallentsorgungsdienst oder den Händler, bei dem das Produkt gekauft wurde. **DIESES GERÄT ENTSPRICHT DER RICHTLINIE RoHS011/65/EG.**

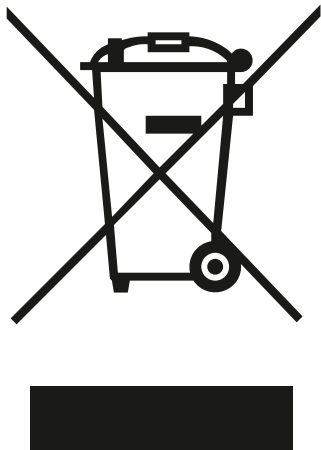

Der Apparat enthält Öl, entflammbares Kühlgas, Kunststoffteile und Glas. Achtung! Die Polyurethalisolierung enthält Cyclopentanon als Treibgas, eine nicht umweltbelastende aber entflammbare Substanz. Um maximalen Umweltschutz bei der Entsorgung zu garantieren, empfehlen wir, das Gerät nicht in der Umwelt abzustellen. Werfen Sie die Verpackung des Geräts nicht in den allgemeinen Müll, sondern sortieren Sie die verschiedenen Materialien, wie Styropor, Karton, Plastiktüten. Die Demontage des Geräts und die Wiederverwertung der Komponenten hat unter Beachtung der lokalen gültigen Normen zu erfolgen.

Wenn das Gerät außer Betrieb gesetzt wird:

- Ziehen Sie den Netzstecker.
- Durchtrennen Sie das Netzkabel und entsorgen Sie es gemeinsam mit dem Netzstecker.
- Belassen Sie alle Zubehörteile in der Wanne, um Kindern das Klettern in das Gerätekühlfach zu erschweren.
- Es ist Kindern untersagt, mit dem stillgelegten Gerät zu spielen. Erstickungsgefahr!
- Der Kühlkreislauf des Geräts enthält ein entzündliches Gas, welches separat entsorgt werden muss. Die Teile des Kältekreislaufs dürfen während der Entsorgung des Geräts nicht beschädigt werden.

Die zum Kühlkreislauf gehörigen Bauteile dürfen erst zerlegt und/oder abgetrennt werden, nachdem der Kühlkreislauf entleert wurde und das Kältegas durch qualifiziertes Personal aufgefangen wurde.

Modello - Modèle - Model Modell - Modelo - Modelo	EPTABRICKS 2.0 OUTDOOR	
Fabbricante - Constructeur - Manufacturer Hersteller - Fabricante - Fabricante	Epta Spa - Via Mecenate, 86 - 20138 Milano (MI) ITALIA Tel. 02/55403211 Telefax 02/55401023	27/27

11. ALLGEMEINE ERGÄNZENDE HINWEISE

Hinweise zur korrekten Installation und Wartung

Alle Hinweise zur Installation und Wartung finden Sie im Benutzerhandbuch auf der folgenden Webseite:

www.eptarefrigeration.com.

Die Installationsanleitungen für qualifiziertes Fachpersonal sind in an folgender Stelle verfügbar:

- beim Kundenservice
- Im Lieferumfang einiger Produktkategorien ist die Installationsanleitung in Papierform enthalten

Professioneller Reparaturservice

Dieses Angebot wird von unseren Servicestellen für Sie bereitgestellt, Sie finden die Informationen unter dem folgenden Link: www.eptarefrigeration.com.

Ersatzteile

Ersatzteile und Reparaturhinweise für das Gerät sind mindestens noch 8 Jahre, nachdem die Produktion eingestellt wurde, unter der folgenden Adresse verfügbar: www.epta-service.com/service.

Für die erforderlichen Zugangsdaten senden Sie bitte eine E-Mail an: servicesupport@eptarefrigeration.com.

Reinigung des luftgekühlten Kondensators

Damit sich die Leistung von Geräten mit integriertem Aggregat und luftgekühltem Kondensator nicht verschlechtert, muss der Kondensator gemäß der Vorgaben sowie in den vorgegebenen Zeitabständen gereinigt werden, wie im Installations- und Wartungshandbuch beschrieben.

Wichtiger Hinweis zur Lebensmittelverschwendung

Es wird empfohlen, die Lagerungshinweise auf den Produktverpackungen und die Anweisungen der Lebensmittelhersteller sorgfältig zu beachten.

Die Temperatureinstellungen müssen dabei gemäß den Angaben in unserer technischen Dokumentation an die Konservierungseigenschaften der Lebensmittel angepasst werden.

Unsachgemäßer Gebrauch kann zum vorzeitigen Verderb von Lebensmitteln führen.

Umgebungsbedingungen

Dieses Gerät ist für den Einsatz in einer Umgebung vorgesehen, in der die Temperatur und die Luftfeuchtigkeit innerhalb der in der Bedienungsanleitung angegebenen Bereiche liegen.

Anweisungen zur Demontage

Die Demontage muss durch qualifizierte Fachkräfte erfolgen.

Die Epta-Gruppe legt seit jeher großen Wert auf den Schutz der Umwelt. Sie stellt Ihnen die Anleitungen zur Demontage und Abfallbehandlung von steckerfertigen Kühlgeräten unter folgendem Link zum Herunterladen zur Verfügung.

- Handbuch zur Demontage offener Plugin-Modelle



- Handbuch zur Demontage geschlossener Plugin-Modelle:



Weitere Informationen

Bitte wenden Sie sich für nähere Informationen an die folgende Adresse www.eptarefrigeration.com und an sie Produktdatenbank EPREL. Sie können diese Seite aufrufen, indem Sie den QR-Code auf dem Energielabel Ihres Geräts scannen.



Modello - Modèle - Model Modell - Modelo - Modelo	EPTABRICKS 2.0 OUTDOOR	
Fabbricante - Constructeur - Manufacturer Hersteller - Fabricante - Fabricante	Epta Spa - Via Mecenate, 86 - 20138 Milano (MI) ITALIA Tel. 02/55403211 Telefax 02/55401023	1/27

CONTENT

1. Introduction	2	IT
2. Safety warnings	3	FR
2.1 Warnings for appliances using R290 (propane) and R600a (isobutane)	3	
2.2 General warnings	3	
2.3 Warnings for cabinet maintenance	4	EN
2.4 Electrical warnings	5	
2.5 Prohibitions	5	DE
3. General description	6	
3.1 Sections	7	ES
4. Transportation of the cabinet	10	
5. Ambient conditions	11	PT
6. Ambient conditions	12	
7. Technical features	13	
8. Use of cabinet	14	
9. Ordinary maintenance	16	
9.1 Cleaning the cabinet	16	
9.2 Water collection tank cleaning	16	
10. User indications	17	
10.1 Description of the cabinet	17	
10.2 Transport and handling	17	
10.3 Receipt and storage	17	
10.4 Installation and ambient conditions	18	
10.5 Electrical connection	18	
10.6 Technical features	18	
10.7 Loading the product	19	
10.8 Access	19	
10.9 Cleaning and ordinary maintenance	23	
10.10 Emergency situations	24	
10.11 Technical assistance	25	
10.12 Dismantling and elimination	25	
11. Supplementary general warnings	27	

SYMBOLS USED

Prohibition symbol: it prohibits the carrying out of specific operations.



Attention symbol: accident prevention rules for the operator.



Warning symbol: it is possible to damage the refrigeration door and/or its components



Note symbol: it provides useful information.

Modello - Modèle - Model Modell - Modelo - Modelo	EPTABRICKS 2.0 OUTDOOR	 Epta
Fabbricante - Constructeur - Manufacturer Hersteller - Fabricante - Fabricante	Epta Spa - Via Mecenate, 86 - 20138 Milano (MI) ITALIA Tel. 02/55403211 Telefax 02/55401023	2/27

1. INTRODUCTION

It is recommended to attentively read the content of this Manual and keep it together with the cabinet.

The manufacturer shall not be held liable for any harm caused to people or damage to property due to the failure to observe the warnings contained in this Manual.



Fig. 1

The Manual contains information considered necessary for the good use and operation of the cabinet.

Inside you will find the following descriptions and information:

- a functional description of the cabinet and each of its parts
- information on the safety of the cabinet and the safety rules to follow
- a correct use of the cabinet
- a correct ordinary and programmed maintenance, including cleaning operations

For the correct installation of the cabinet refer to the following documents:

- Quick Reference Instructions

This Manual is for the following professional figures:

- **QUALIFIED OPERATOR:** a qualified person, educated to operate, regulate, clean and carry out ordinary maintenance on the cabinet
- **SPECIALISED TECHNICIAN** a technician trained and authorised by the body indicated in the contract (manufacturer/concessionaire/distributor) to carry out: installation, non-routine maintenance, repair, replacement and overhaul of the cabinet

Instructions for use are also available on: www.eptarefrigeration.com.

Make reference to the declaration of conformity for the regulations and certifications of the cabinet.

Always keep the instruction booklet and in case of sale.

Modello - Modèle - Model Modell - Modelo - Modelo	EPTABRICKS 2.0 OUTDOOR	
Fabbricante - Constructeur - Manufacturer Hersteller - Fabricante - Fabricante	Epta Spa - Via Mecenate, 86 - 20138 Milano (MI) ITALIA Tel. 02/55403211 Telefax 02/55401023	3/27

2. SAFETY WARNINGS

2.1 Warnings for appliances using R290 (propane) and R600a (isobutane)

 Isobutane and propane are natural gases without effects on the environment, but inflammable. It is therefore essential to make sure that none of the pipes of the cooling circuit are damaged before connecting the cabinets to the power supply network. The room where the cabinet is installed must have a minimum volume of 1m³ for each 8g of refrigerant. The amount of refrigerant of the cabinet is indicated on the technical data plate on the cabinet itself. In the event of refrigerant leak, make sure there are no naked flames or ignition sources close to the leakage point.

 Do not damage the refrigeration circuit.

 In order to reduce flammability-related risks, this cabinet may only be installed by suitably qualified personnel.

 Do not damage internal or external walls of the machine: the cooling fluid circuit may damage. In case of damaged walls do not start the machine and refer to a service centre.

2.2 General warnings

 The manufacturer disclaims any liability for damage caused to people or property due to the failure to observe the warnings contained in this manual. Any person who uses this cabinet must read this user manual.

 The employer must educate staff on the risks of accidents, on the devices arranged for staff safety, on the risks of noise emission and on the general safety rules provided for by the rules in force.

 The cabinet must be used by adults in possession of the necessary knowledge and whose physical, sensory or mental abilities are not impaired; the cabinet is not designed for use by minors (in particular from 0 to 3 years). Children, under the supervision and responsibility of adults, must not play with the cabinet.

 Any other use not explicitly indicated in this manual is considered dangerous and the manufacturer cannot be held liable for any damage deriving from improper, wrong and unreasonable use.

 The cabinet must be used by staff equipped with the appropriate personal protection equipment.

 It is compulsory to use work gloves.

 Do not leave the cabinet exposed to weathering agents

 Do not use direct or indirect jets of water on the cabinet.

 Do not touch the bench with wet or damp hands and feet; do not use the cabinet with naked feet.

IT

FR

EN

DE

ES

PT

Modello - Modèle - Model Modell - Modelo - Modelo	EPTABRICKS 2.0 OUTDOOR	
Fabbricante - Constructeur - Manufacturer Hersteller - Fabricante - Fabricante	Epta Spa - Via Mecenate, 86 - 20138 Milano (MI) ITALIA Tel. 02/55403211 Telefax 02/55401023	4/27

User manual

IT
FR
EN
DE
ES
PT



The removal of protection devices or panels that require the use of tools to be removed is reserved exclusively for qualified personnel.



This cabinet is designed for the use, transport and storage of up to a maximum altitude of 2000 m above sea level.



For assembling dedicated optional accessories, contact your nearest authorised service centre.



Each intervention must be carried out exclusively by qualified personnel and, in every case, before each intervention the power supply of the cabinet must be disconnected.



Instruct anyone who uses the cabinet on the position of the disconnecter switch.



Thermostat adjustment is reserved for the technical after-sales service only.



Pay attention to the hot or moving parts marked with the appropriate symbol.



In case of fire, do not use water to put out the flames but only dry fire extinguishers



Cabinet must be installed on a perfectly even surface.



Avoid fire or sparks inside the appliance.



Keep the ventilation openings in the appliance housing free from obstructions.



Do not use electrical appliances inside the compartments of the appliance for the preservation of frozen foods if these are not the type recommended by the manufacturer.



Do not store explosive or dangerous substances, such as containers under pressure with flammable propellant, in this appliance.



Do not leave weights on top of the cabinet roof Resting unpacked products directly on the shelves should be avoided, use suitable food containers.



Do not place liquid containers and do not pour liquids on the counter.

2.3 Warnings for cabinet maintenance



Access to the electrical parts and/or parts that require the use of tools is reserved for specialist technicians.



Prior to any maintenance and cleaning operation reserved for the user, de-energise the cabinet using the wall-mounted disconnecter switch.



Pay attention to the hot or moving parts marked with the appropriate symbol.





It is compulsory to use work gloves.

Modello - Modèle - Model Modell - Modelo - Modelo	EPTABRICKS 2.0 OUTDOOR	
Fabbricante - Constructeur - Manufacturer Hersteller - Fabricante - Fabricante	Epta Spa - Via Mecenate, 86 - 20138 Milano (MI) ITALIA Tel. 02/55403211 Telefax 02/55401023	5/27

2.4 Electrical warnings

 Ensure that the power voltage corresponds to the rating plate of the cabinet.

 The electrical installation must be carried out in a competent manner by specialised technicians.

 The removal of the cover of the electrical panel is reserved for specialist technicians.

 In compliance with the installation rules, the power supply must include an omnipolar disconnection device, which ensures complete disconnection from the network in overvoltage category III conditions.

 The cabinet must be installed following the instructions of the manufacturer, by professionally qualified staff and in compliance with the rules on electrical systems in force in individual Countries.

 A wrong cabinet installation can cause damage to people, animals or property, for which the manufacturer cannot be held liable.

 If the power cord is damaged, it must be replaced by authorized service personnel. Do not attempt to repair the cable.

 Do not power the bench if it is damaged. If in doubt, contact the after-sales service or your dealer.

 After installing the bench, make sure it does not rest on the power cable.

 For connection, never use reductions, extensions, adaptors or multi-sockets. Connection of the columns must take place **DIRECTLY** on the power supply mains.

2.5 Prohibitions

 It is forbidden to use devices in addition to those provided in the cabinet by the manufacturer to accelerate the defrosting process.

 It is forbidden for unskilled staff to remove the cover of the electrical panel or open panels that require the use of tools.

 It is forbidden to use the cabinet for the preservation and/or display of explosive, flammable or corrosive substances, such as spray cans containing a flammable propellant.

 It is forbidden to use the cabinet for the preservation and/or display of pharmaceutical products.

 In case of **PRODUCTS NOT PACKAGED OR PRESERVED AT LOW TEMPERATURE**, it is prohibited to use the cabinet for the preservation and/or display of bottles and packages in glass.

 It is forbidden to place the cabinet in areas with the presence of explosive gaseous substances.

 It is forbidden to remove the identification plate from the cabinet.

 It is forbidden to get on the counter or on the counter bumper.

IT

FR

EN

DE

ES

PT

Modello - Modèle - Model Modell - Modelo - Modelo	EPTABRICKS 2.0 OUTDOOR	
Fabbricante - Constructeur - Manufacturer Hersteller - Fabricante - Fabricante	Epta Spa - Via Mecenate, 86 - 20138 Milano (MI) ITALIA Tel. 02/55403211 Telefax 02/55401023	6/27

User manual

3. GENERAL DESCRIPTION

- IT
- FR
- EN**
- DE
- ES
- PT

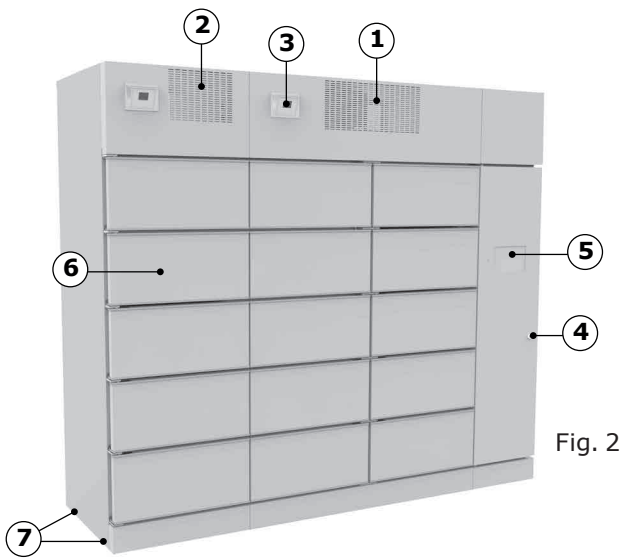

Fig. 2

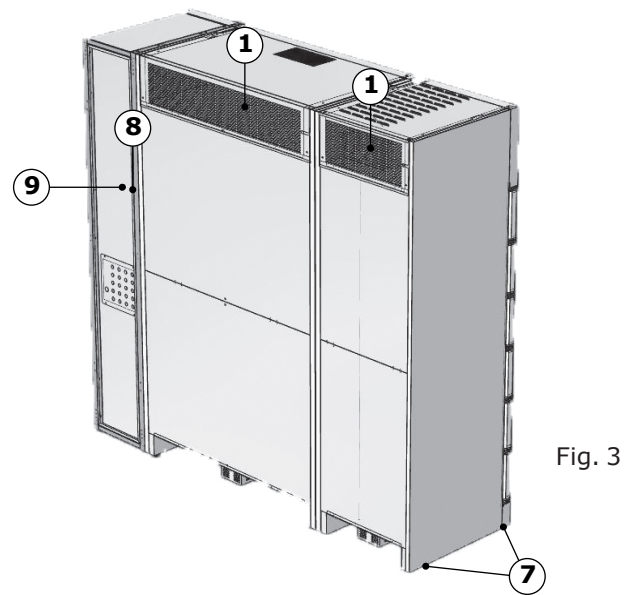

Fig. 3

1. Motor compartment
2. Front cover
3. Electronic control
4. Lock
5. Display and Qr code reader
6. Doors
7. Adjustable feet
8. Antenna wire
9. Power cord

Modello - Modèle - Model Modell - Modelo - Modelo	EPTABRICKS 2.0 OUTDOOR	
Fabbricante - Constructeur - Manufacturer Hersteller - Fabricante - Fabricante	Epta Spa - Via Mecenate, 86 - 20138 Milano (MI) ITALIA Tel. 02/55403211 Telefax 02/55401023	7/27

3.1 Sections

EPTABRICKS OUTDOOR BT 5 DOORS

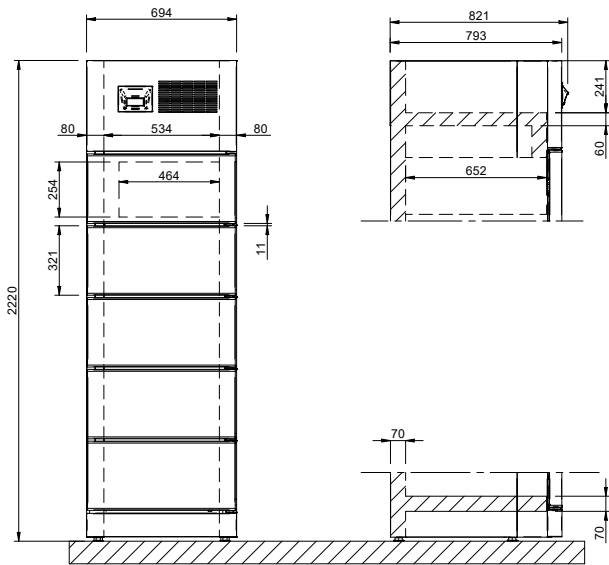

Fig. 4

EPTABRICKS OUTDOOR TN-AMBIENT 6 DOORS

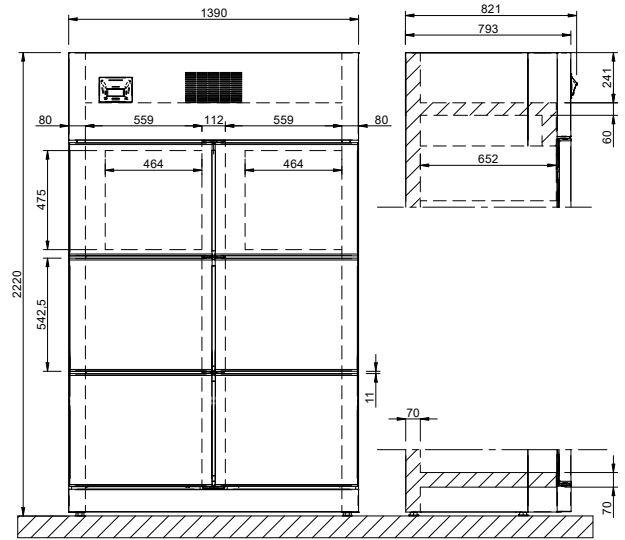

Fig. 6

EPTABRICKS OUTDOOR TN-AMBIENT 8 DOORS

EPTABRICKS OUTDOOR BT 6 DOORS

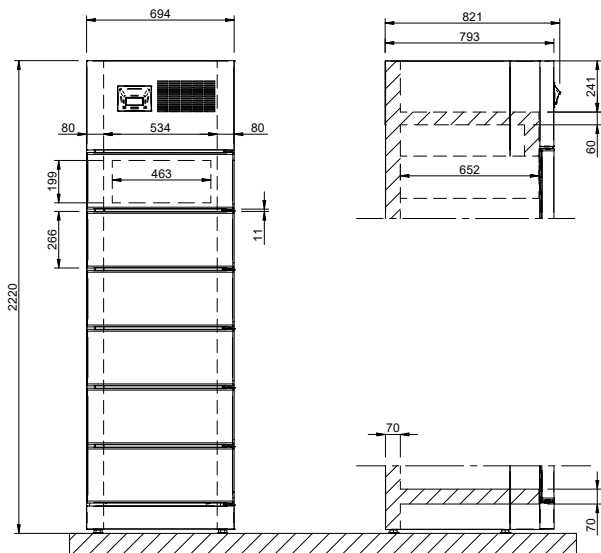

Fig. 5

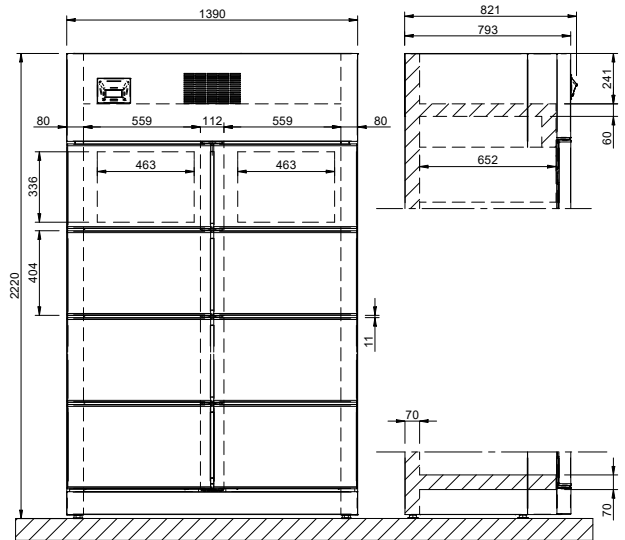

Fig. 7

Modello - Modèle - Model Modell - Modelo - Modelo	EPTABRICKS 2.0 OUTDOOR	
Fabbricante - Constructeur - Manufacturer Hersteller - Fabricante - Fabricante	Epta Spa - Via Mecenate, 86 - 20138 Milano (MI) ITALIA Tel. 02/55403211 Telefax 02/55401023	8/27

User manual

IT

FR

EN

DE

ES

PT

EPTABRICKS OUTDOOR TN-AMBIENT 10 DOORS EPTABRICKS OUTDOOR DRY 8 DOORS

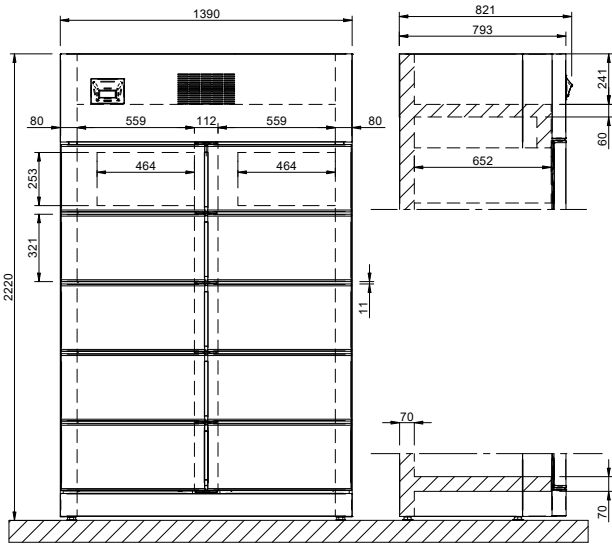

Fig. 8

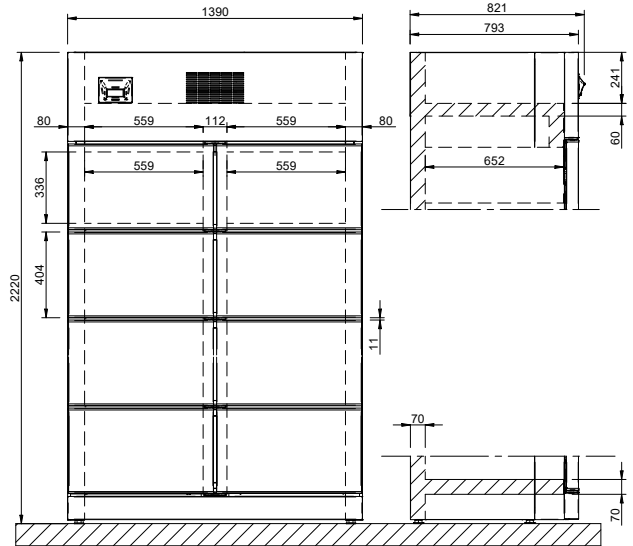

Fig. 10

EPTABRICKS OUTDOOR DRY 6 DOORS

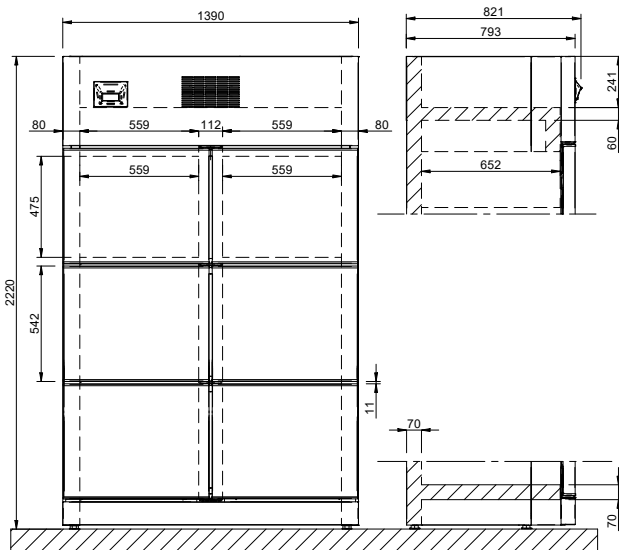

Fig. 9

EPTABRICKS OUTDOOR DRY 10 DOORS

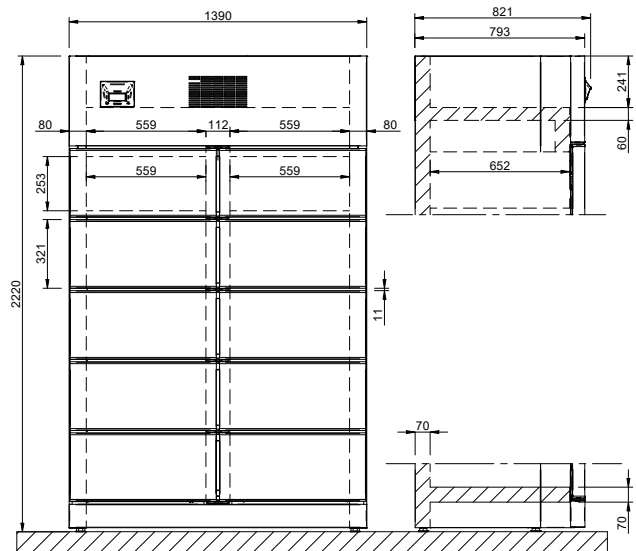

Fig. 11

Modello - Modèle - Model Modell - Modelo - Modelo	EPTABRICKS 2.0 OUTDOOR	
Fabbricante - Constructeur - Manufacturer Hersteller - Fabricante - Fabricante	Epta Spa - Via Mecenate, 86 - 20138 Milano (MI) ITALIA Tel. 02/55403211 Telefax 02/55401023	9/27

EPTABRICKS OUTDOOR MASTER

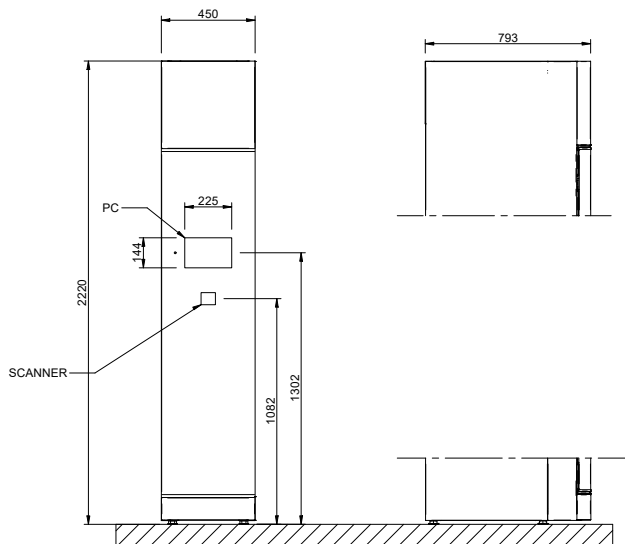

Fig. 12

- IT
- FR
- EN**
- DE
- ES
- PT

Modello - Modèle - Model Modell - Modelo - Modelo	EPTABRICKS 2.0 OUTDOOR	
Fabbricante - Constructeur - Manufacturer Hersteller - Fabricante - Fabricante	Epta Spa - Via Mecenate, 86 - 20138 Milano (MI) ITALIA Tel. 02/55403211 Telefax 02/55401023	10/27

User manual

4. TRANSPORTATION OF THE CABINET

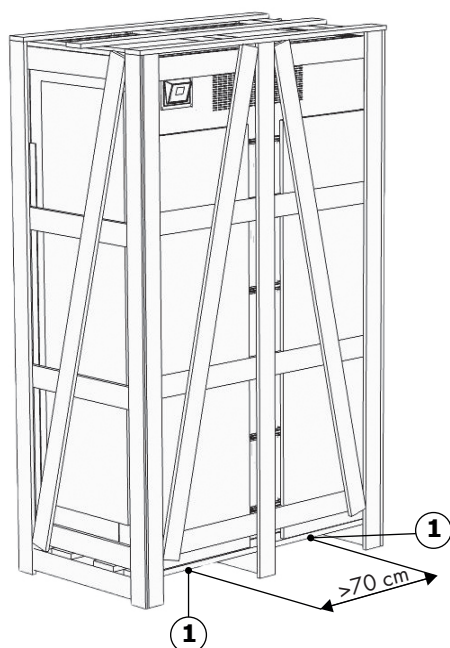

Fig. 13

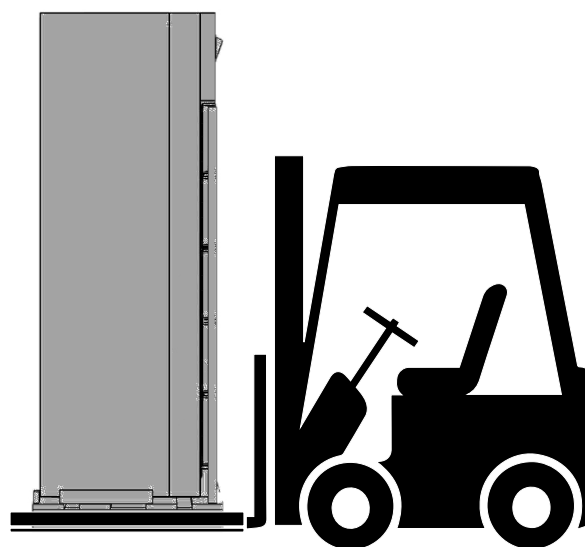

Fig. 14

1. Lifting points

Chart I

Model	Weight (kg)	Weight with packaging (kg)
EPTABRICKS OUTDOOR BT 5 DOORS	140	150
EPTABRICKS OUTDOOR BT 6 DOORS	140	150
EPTABRICKS OUTDOOR TN-AMBIENT 6 DOORS	250	263
EPTABRICKS OUTDOOR TN-AMBIENT 8 DOORS	250	263
EPTABRICKS OUTDOOR TN-AMBIENT 10 DOORS	250	263
EPTABRICKS OUTDOOR DRY 6 DOORS	135	145
EPTABRICKS OUTDOOR DRY 8 DOORS	135	145
EPTABRICKS OUTDOOR DRY 10 DOORS	135	145
EPTABRICKS OUTDOOR MASTER	90	100

Modello - Modèle - Model Modell - Modelo - Modelo	EPTABRICKS 2.0 OUTDOOR	 Epta
Fabbricante - Constructeur - Manufacturer Hersteller - Fabricante - Fabricante	Epta Spa - Via Mecenate, 86 - 20138 Milano (MI) ITALIA Tel. 02/55403211 Telefax 02/55401023	11/27

5. AMBIENT CONDITIONS

IT

FR

EN

DE

ES

PT

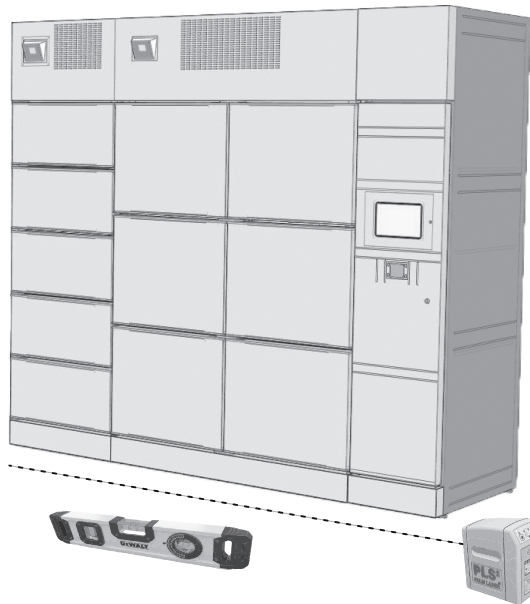

Fig. 15

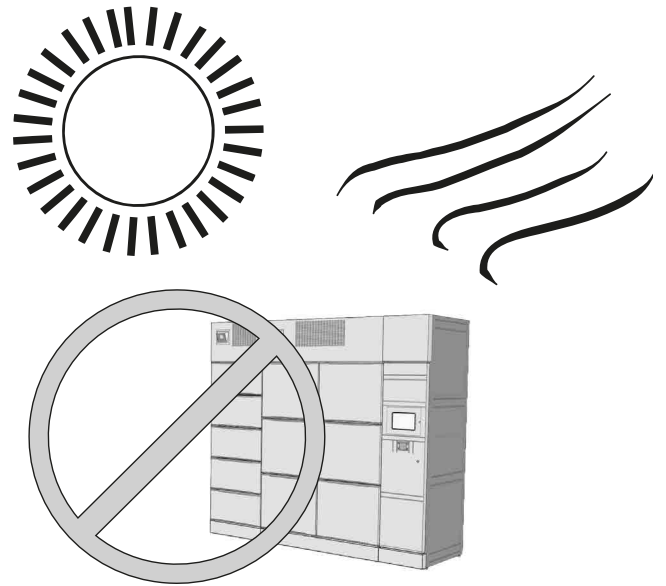

Fig. 17

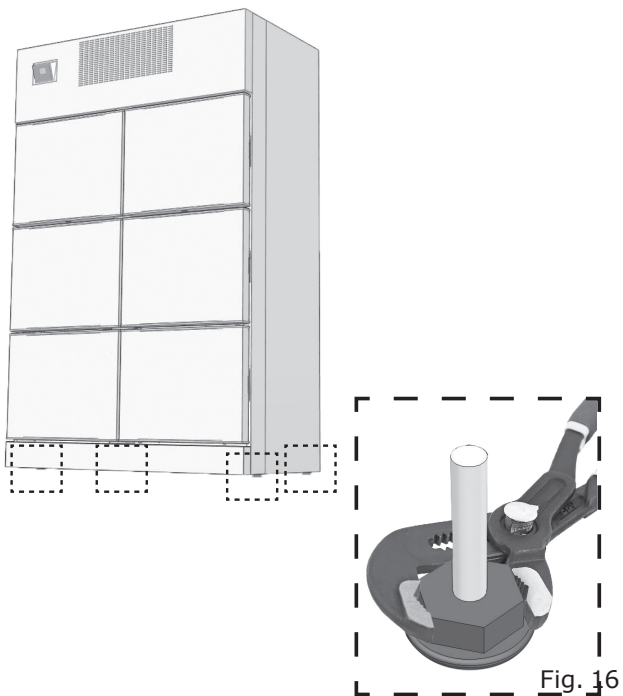

Fig. 16

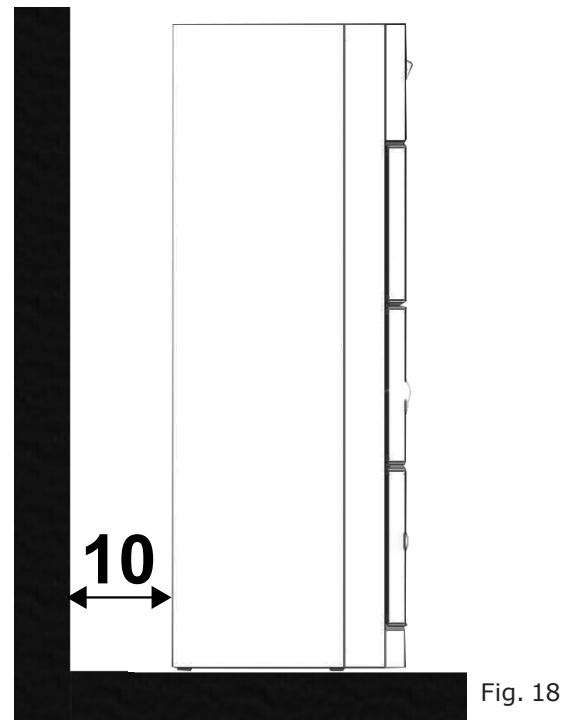

Fig. 18

Modello - Modèle - Model Modell - Modelo - Modelo	EPTABRICKS 2.0 OUTDOOR	
Fabbricante - Constructeur - Manufacturer Hersteller - Fabricante - Fabricante	Epta Spa - Via Mecenate, 86 - 20138 Milano (MI) ITALIA Tel. 02/55403211 Telefax 02/55401023	12/27

6. AMBIENT CONDITIONS

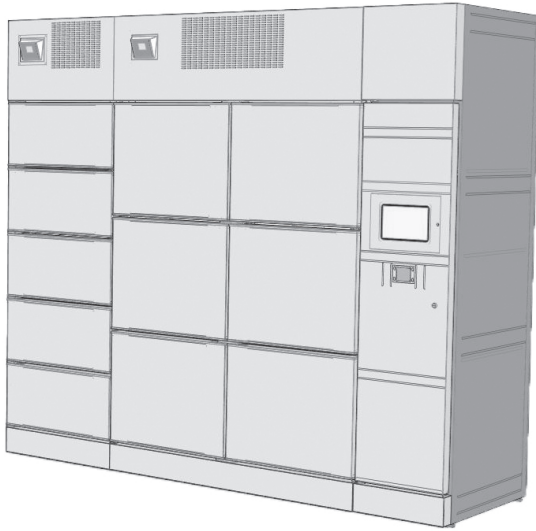

Fig. 19

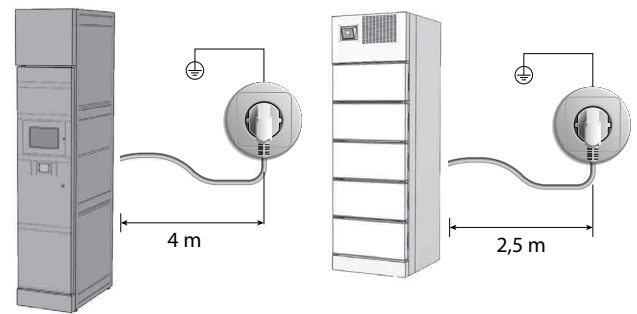

Fig. 20

Chart II

Ambient Characteristics	
Type	Max Value
Temperature	35°C
Relative humidity	75 %

Modello - Modèle - Model Modell - Modelo - Modelo	EPTABRICKS 2.0 OUTDOOR	
Fabbricante - Constructeur - Manufacturer Hersteller - Fabricante - Fabricante	Epta Spa - Via Mecenate, 86 - 20138 Milano (MI) ITALIA Tel. 02/55403211 Telefax 02/55401023	13/27

7. TECHNICAL FEATURES

 <small>EPTA S.p.A. Via Mecenate, 86 20138 Milano - Italy</small>		12	
1		2	
3		4	
5		6	
7		8	
9		10	
11		12	
13		14	
15		16	
17		18	
19		20	
21		22	
23		24	
25		CE	

Fig. 21

- | | |
|-----------------------------------|---------------------------|
| 1. Origin of the product | 14. Date of production |
| 2. Product in "Country of origin" | 15. Hat Code |
| 3. Rated voltage | 16. Model |
| 4. Rated power | 17. Type of refrigerant 1 |
| 5. Rated frequency | 18. Refrigerant mass 1 |
| 6. Rated current | 19. Type of refrigerant 2 |
| 7. Defrosting power | 20. Refrigerant mass 2 |
| 8. Defrosting current | 21. Climate class |
| 9. Heating system | 22. Gas isolation |
| 10. Lighting system | 23. Protection index |
| 11. Operator manual | 24. Certification brands |
| 12. Barcode | 25. WEEE brand |
| 13. Serial number | |



Warning: it contains flammable refrigerant gas.

Chart III

Quantity of refrigerant R290 (g)	
Model	Quantity (g)
EPTABRICKS OUTDOOR BT	-
EPTABRICKS OUTDOOR TN	-
EPTABRICKS OUTDOOR AMBIENT	-

Modello - Modèle - Model Modell - Modelo - Modelo	EPTABRICKS 2.0 OUTDOOR	 Epta
Fabbricante - Constructeur - Manufacturer Hersteller - Fabricante - Fabricante	Epta Spa - Via Mecenate, 86 - 20138 Milano (MI) ITALIA Tel. 02/55403211 Telefax 02/55401023	14/27

- IT
- FR
- EN
- DE
- ES
- PT

8. USE OF CABINET

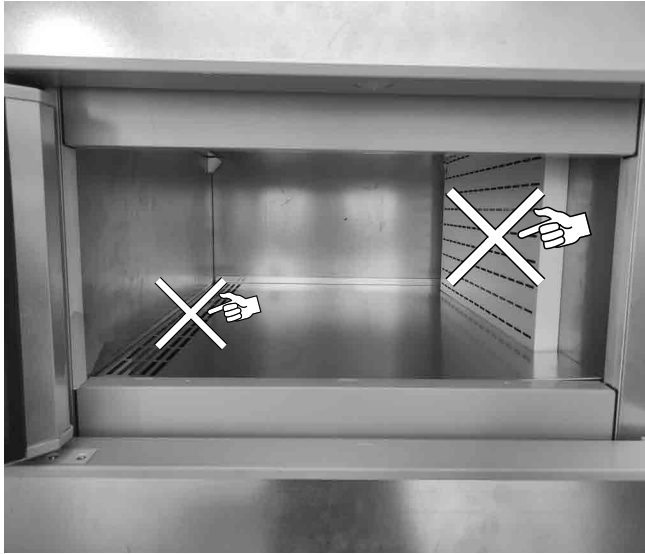

Fig. 22

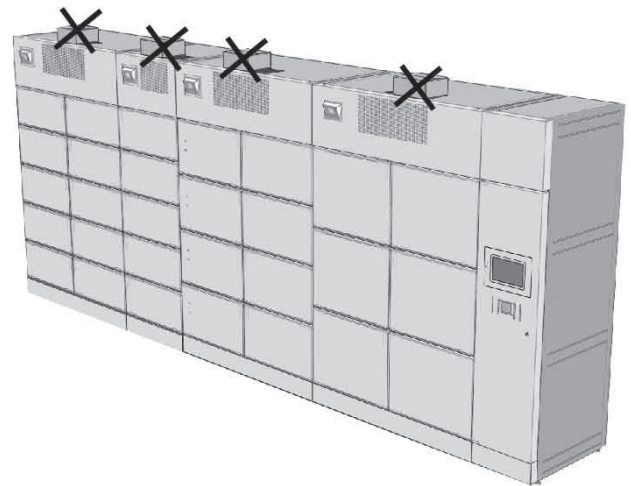



Fig. 24

 Do not cover

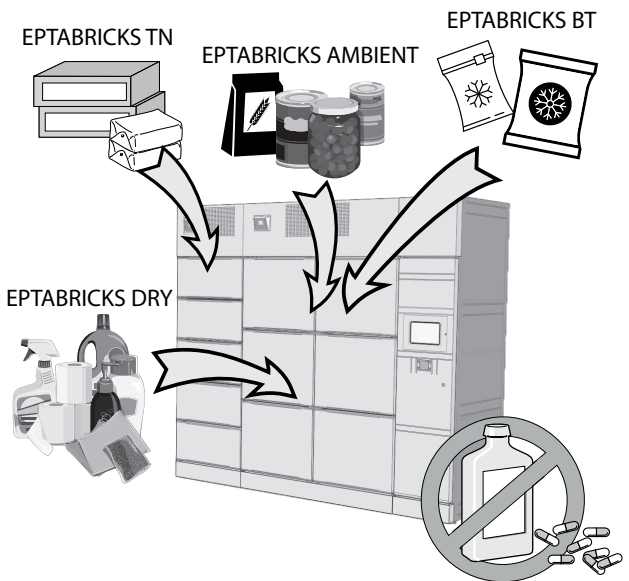

Fig. 23

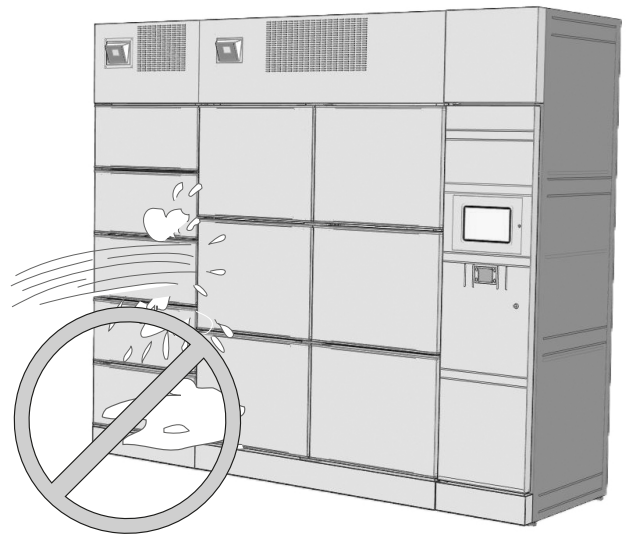

Fig. 25

Modello - Modèle - Model Modell - Modelo - Modelo	EPTABRICKS 2.0 OUTDOOR	 Epta
Fabbricante - Constructeur - Manufacturer Hersteller - Fabricante - Fabricante	Epta Spa - Via Mecenate, 86 - 20138 Milano (MI) ITALIA Tel. 02/55403211 Telefax 02/55401023	15/27

- IT
- FR
- EN**
- DE
- ES
- PT

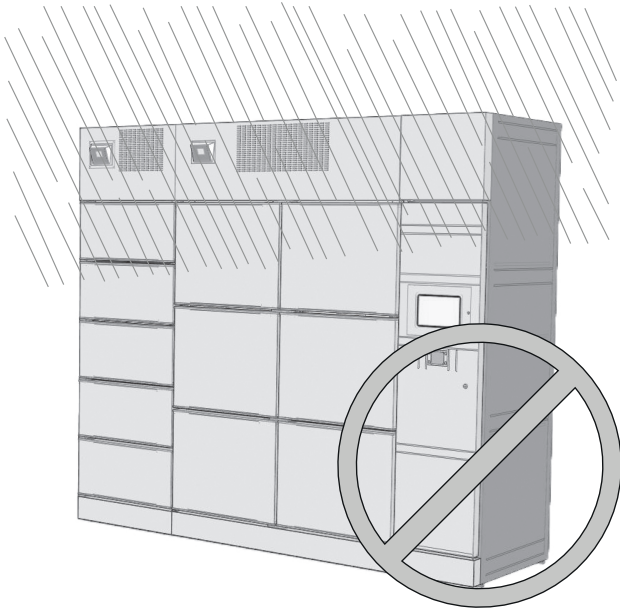

Fig. 26

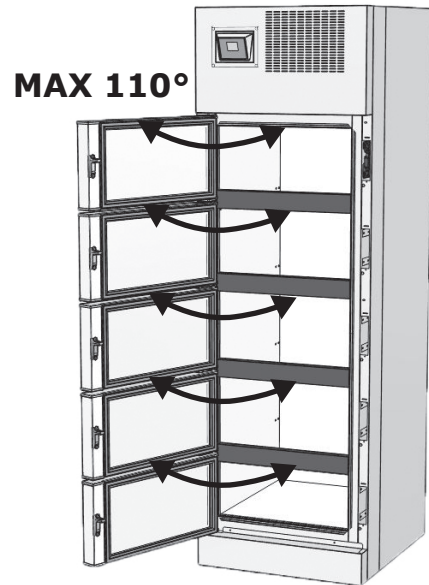

Fig. 28

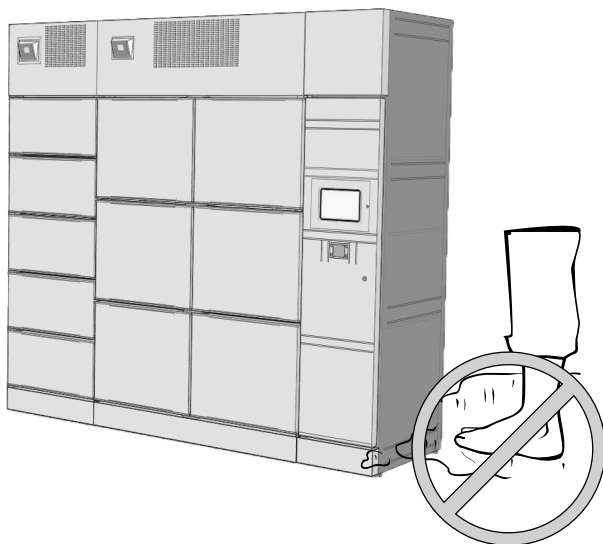

Fig. 27

Modello - Modèle - Model Modell - Modelo - Modelo	EPTABRICKS 2.0 OUTDOOR	
Fabbricante - Constructeur - Manufacturer Hersteller - Fabricante - Fabricante	Epta Spa - Via Mecenate, 86 - 20138 Milano (MI) ITALIA Tel. 02/55403211 Telefax 02/55401023	16/27

9. ORDINARY MAINTENANCE

9.1 Cleaning the cabinet

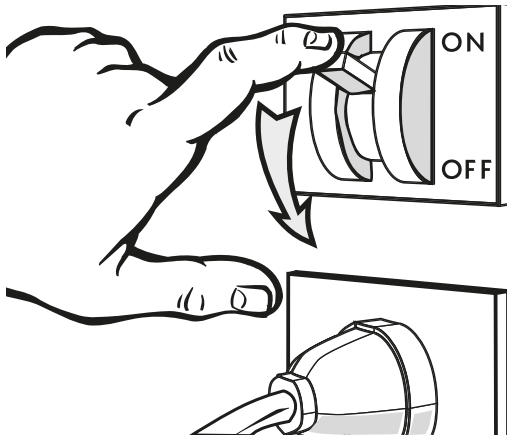

Fig. 29

9.2 Water collection tank cleaning

- Unscrew and remove the lower cover and the tray cover.

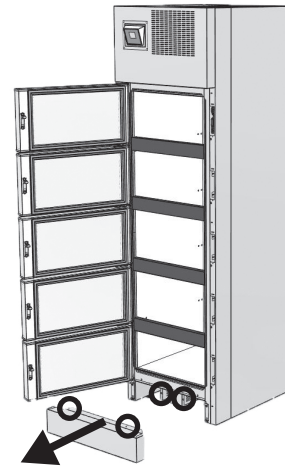

Fig. 31

- Extract and clean the water tray.

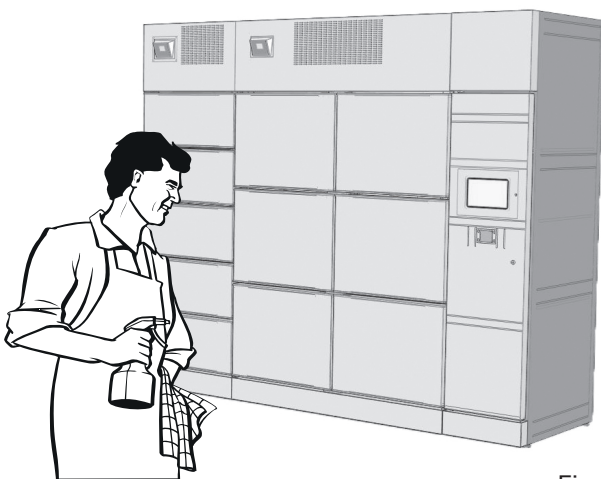

Fig. 30



Fig. 32



Clean based on use and need and in particular environmental conditions (e.g. high humidity, low room temperature, presence of dust, etc.) to avoid incorrect and incomplete evaporation of water and/or presence of unpleasant odours.

Modello - Modèle - Model Modell - Modelo - Modelo	EPTABRICKS 2.0 OUTDOOR	
Fabbricante - Constructeur - Manufacturer Hersteller - Fabricante - Fabricante	Epta Spa - Via Mecenate, 86 - 20138 Milano (MI) ITALIA Tel. 02/55403211 Telefax 02/55401023	17/27

10. USER INDICATIONS

10.1 Description of the cabinet

EptaBricks Tn was designed and manufactured exclusively for the display of fresh packed food, drinks and dairies.

The Eptabricks BT equipment must exclusively be used to sell frozen products.

The Eptabricks AMBIENT equipment must exclusively be used to sell products which do not require extended refrigeration.

The Eptabricks AMBIENT equipment must exclusively be used to sell products NO FOOD.

TEMPERATURE CLASS EPTABRICKS TN (suivant EN-ISO 23953-2): 7M2.

TEMPERATURE CLASS EPTABRICKS BT (suivant EN-ISO 23953-2): 7L1.

TEMPERATURE CLASS EPTABRICKS AMBIENT (suivant EN-ISO 23953-2): 7S.

During transport and handling, receipt and storage, installation, loading, use, cleaning and maintenance, dismantling, pay attention to the risk of overturning the cabinet ("Fig. 33").

The general characteristics and the dimensions are illustrated in the figures and in the sections contained in "General description" (to pg. "7").

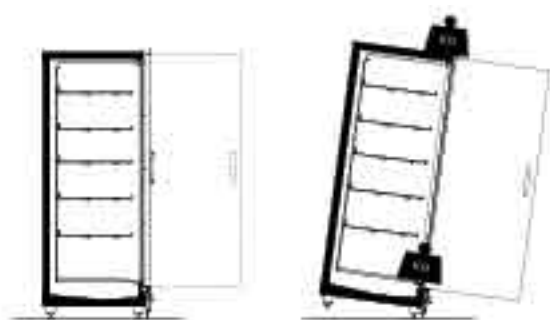

Fig. 33

10.2 Transport and handling

The cabinet is contained in a specific packaging equipped with a platform for handling with forklift trucks.

To transport and handle the cabinet use:

- Exclusively a dedicated or equivalent platform
- A manual or electric forklift suited to lifting the cabinet, with characteristics that comply with current Standards

The weights of the cabinet (empty and with packaging) and the dimensions of the packaging are shown in "Transportation of the cabinet" (chart "Chart I" and figures at pg."11").

The handling operations must be carried out by qualified staff able to assess weights, lifting points and most suitable means in terms of safety and capacity.

10.3 Receipt and storage

Check conditions of the packaging before accepting the cabinet from the carrier.

If there is obvious damage in the packaging:

- Remove the packaging of the cabinet in the presence of the carrier.
- Sign the delivery document with reservation

The manufacturer shall not be held responsible for any damage caused due to transport or incorrect storage of the cabinet.

The cabinet must be stored in a place sheltered from sun and weather, with a temperature of between -25°C and +55°C and a relative humidity of the air between 30% and 95%.

Modello - Modèle - Model Modell - Modelo - Modelo	EPTABRICKS 2.0 OUTDOOR	
Fabbricante - Constructeur - Manufacturer Hersteller - Fabricante - Fabricante	Epta Spa - Via Mecenate, 86 - 20138 Milano (MI) ITALIA Tel. 02/55403211 Telefax 02/55401023	18/27

10.4 Installation and ambient conditions

The cabinet is not designed to be installed outdoors.

For a correct operation of the cabinet, ensure that it is positioned:

- On a levelled floor ("Fig. 15").
- The equipment is equipped with adjustable feet, to stop and position the equipment ("Fig. 16"). It is strictly necessary after positioning to stabilise the equipment on the ground.
- It's most important that the compressor unit, situated on the upper part of the column, is always covered by a protection roof. Don't leave exposed directly to the rainfall and to the bad weather. ("Fig. 17").
- It is fundamental to comply with the distances indicated "Fig. 18" (cm) for correct installation of the equipment.

Provide the space necessary for the use of the cabinet by the client.

The ambient conditions in which the cabinet should be placed are set out in "Ambient conditions".

10.5 Electrical connection



If the cabinet has been sharply tilted while being sited or for mounting of accessories, it must be left to stand for at least three hours before being started to allow the lubricating oil to settle in the compressor. Failure to do so can cause total destruction of the compressor refrigerating system.



THE ELECTRICAL SUPPLY LINE TO WHICH THE REFRIGERATOR WILL HAVE TO BE CONNECTED IS TO BE PROTECTED BY A VERY SENSITIVE DIFFERENTIAL SWITCH (Rc=16A,Dc=30mA); IT IS ALSO TO BE LINKED TO THE GENERAL EARTHING PLANT. Earthing is necessary and compulsory by law.

An omnipolar disconnect switch must be installed upstream of the cabinet. This must have:

- Minimum distance of the contacts of 3 mm
- Adequate breaking power

The cable should be fully extended and located where it is unlikely to be struck, caught or stepped on, away from water and the other liquids and heat sources and must not be damaged.

The disconnect switch must be placed in a position that makes it easy to operate in emergency situations (maximum distance of 3 m).

Before connecting the cabinet, ensure that the supply voltage corresponds to the rating plate data of the cabinet. To guarantee smooth operation, the maximum voltage variation must be between +/- 6% of the nominal value.

10.6 Technical features

The identification plate shows the characteristic technical data of the cabinet. Its position and the type of data are shown in "Technical features" ("Fig. 21").

Wiring diagrams, control instrument calibration lists, installation instructions and copy of the Declaration of Conformity are available on the website <https://documents.eptarefrigeration.com>.

The sound pressure level generated by the operation of the cabinet is lower than 70 dB(A). The cabinet does not cause harmful vibrations.

Modello - Modèle - Model Modell - Modelo - Modelo	EPTABRICKS 2.0 OUTDOOR	
Fabbricante - Constructeur - Manufacturer Hersteller - Fabricante - Fabricante	Epta Spa - Via Mecenate, 86 - 20138 Milano (MI) ITALIA Tel. 02/55403211 Telefax 02/55401023	19/27

10.7 Loading the product

Energise the cabinet to start its cooling cycle, by acting on the general disconnect switch mounted on the wall. After about 2 hours it is possible to load the cabinet.

The cabinet is suitable to maintain the temperature of the goods and not lower it; the foods, therefore, must be introduced inside it only if already cooled to the respective temperatures of preservation. Products which have been heated must never be introduced into the cabinet.

In loading the goods, ensure that:

- The load is homogeneous in terms of dimension and quality of the products
- The goods do not obstruct the correct flow of refrigerated air ("Fig. 22")
- For good product preservation, always keep approx. 10 cm distance from the upper part of the door compartment.



MAXIMUM ANGLE OF DOOR OPENING = 110°. For correct operation and to avoid any structural failure and/or problems, you need to avoid force opening the doors at an angle over 110°.

Uniformly distributed maximum permissible load: 32 Kg .

10.8 Access

Information for access

The EptaBricks model has EPTA software installed on each collection point. This manual describes access to the software via:

- Client profile
- Deliveries operator profile

Each profile has rights, therefore different menu displays are required.

Warning! The door lock is equipped with a magnetic stop; if the door is opened, opening is signalled with an alarm.

Client profile - Product collection

The MASTER column allows collection of orders, both using scanning/entering the order number and scanning/entering the loyalty card.

For the loyalty card, if the client has multiple orders in the doors, a specific screen will appear with the list of orders which can be collected.

The doors open one by one; to open the next door, you need to close the previous one.

At the end of collection, the client has the possibility of:

- Finishing collection then returning to the initial screen.
- Opening the doors again (if the client is unsure whether an item was forgotten).

If a problem occurs during resetting, an appropriate message will be displayed for the client.

- Access product collection by pressing the central, white key.



**#EPTABricks
24/7**

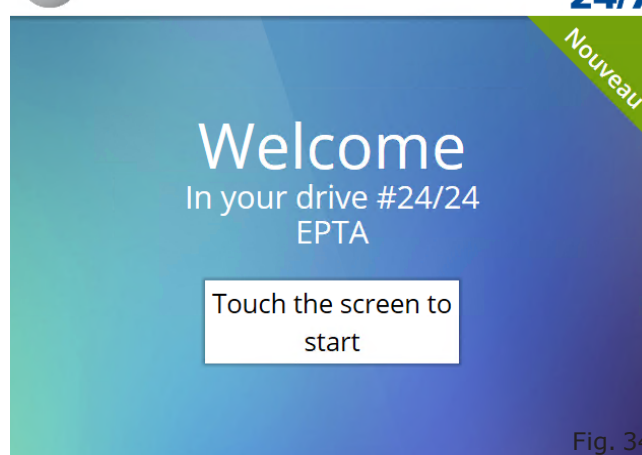

Fig. 34

Modello - Modèle - Model Modell - Modelo - Modelo	EPTABRICKS 2.0 OUTDOOR	
Fabbricante - Constructeur - Manufacturer Hersteller - Fabricante - Fabricante	Epta Spa - Via Mecenate, 86 - 20138 Milano (MI) ITALIA Tel. 02/55403211 Telefax 02/55401023	20/27

User manual

- IT
- FR
- EN**
- DE
- ES
- PT

- Enter the order number on the right of the screen or scan the QR code.

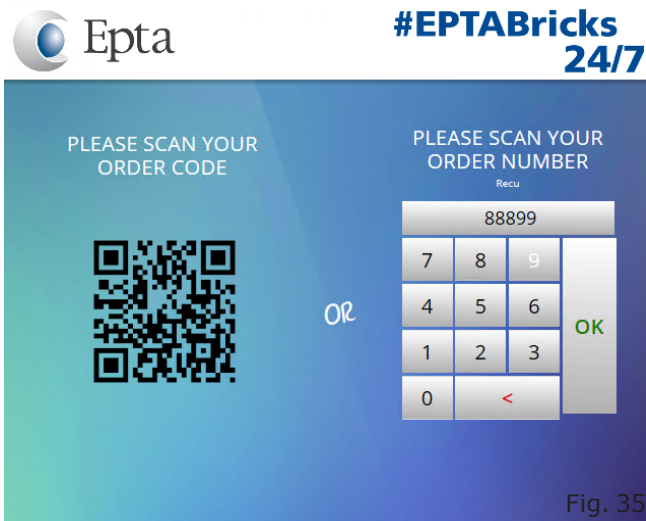

Fig. 35

- Press if goods collection is complete, or if you still want to check the door.



Fig. 37

- Collect the goods from the door signalled on the display of the MASTER column. Having collected the goods, please close the door.

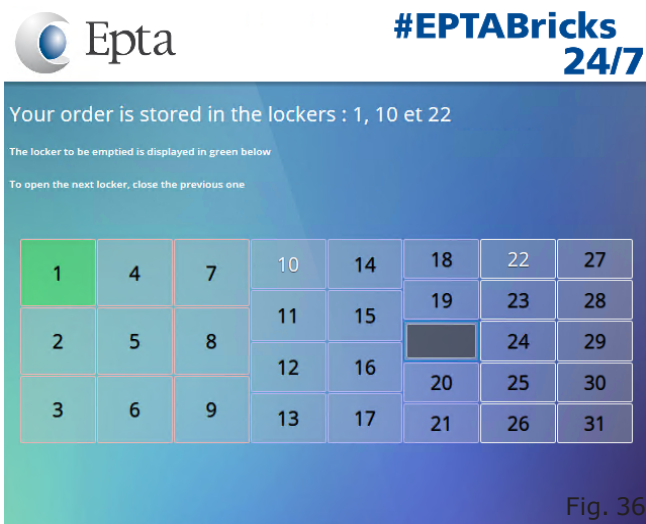

Fig. 36

Deliveries - Product loading operator profile

Creation, enabling and disabling of the delivery accounts take place directly on the collection terminal.

The delivery man can find the free lockers count for each type of temperature, presence of alarms and choice the loading mode:

- **AutoAllocation:** The first door is opened automatically and on closure of the delivery door, the next one will open. If you need to add further doors you can click on additional locker.
- **NoAutoAllocation:** The delivery man chooses which door he could open and it opens by clicking on it.

Modello - Modèle - Model Modell - Modelo - Modelo	EPTABRICKS 2.0 OUTDOOR	 Epta
Fabbricante - Constructeur - Manufacturer Hersteller - Fabricante - Fabricante	Epta Spa - Via Mecenate, 86 - 20138 Milano (MI) ITALIA Tel. 02/55403211 Telefax 02/55401023	21/27

- Access product loading by pressing the central, white key.



Fig. 38

- View the free lockers, select the delivery mode and push the "loading" button.

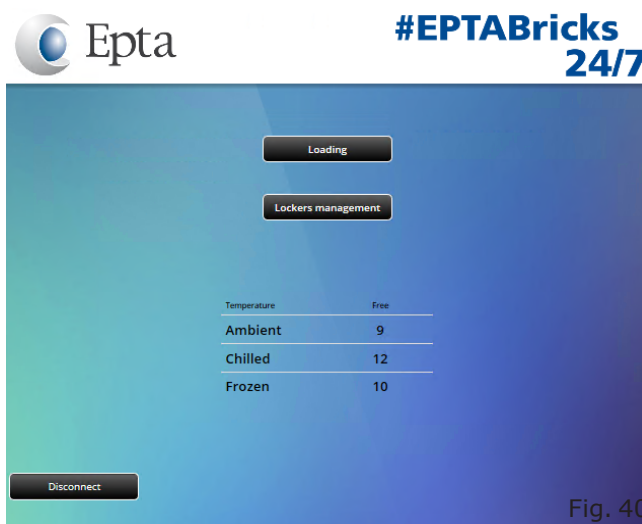

Fig. 40

- Scan/enter the identifier number of the loading operator

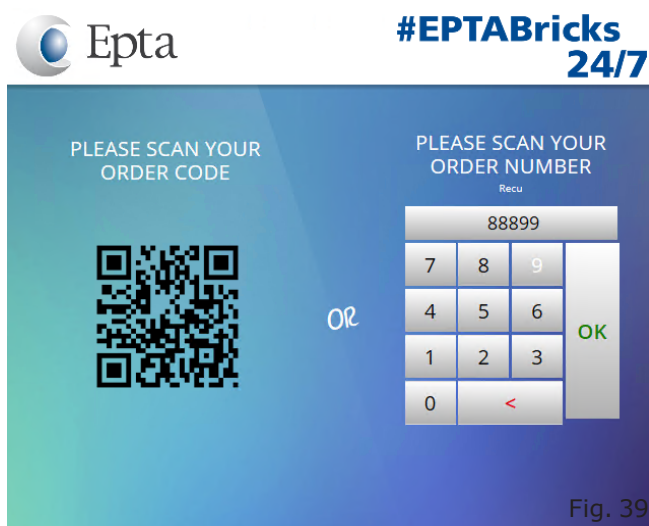

Fig. 39

- Enter the order number of the goods and press OK.



Fig. 41

Modello - Modèle - Model Modell - Modelo - Modelo	EPTABRICKS 2.0 OUTDOOR	
Fabbricante - Constructeur - Manufacturer Hersteller - Fabricante - Fabricante	Epta Spa - Via Mecenate, 86 - 20138 Milano (MI) ITALIA Tel. 02/55403211 Telefax 02/55401023	22/27

User manual

- IT
- FR
- EN
- DE
- ES
- PT

- The door to load will enable and open. As soon as the door is loaded, please close it.

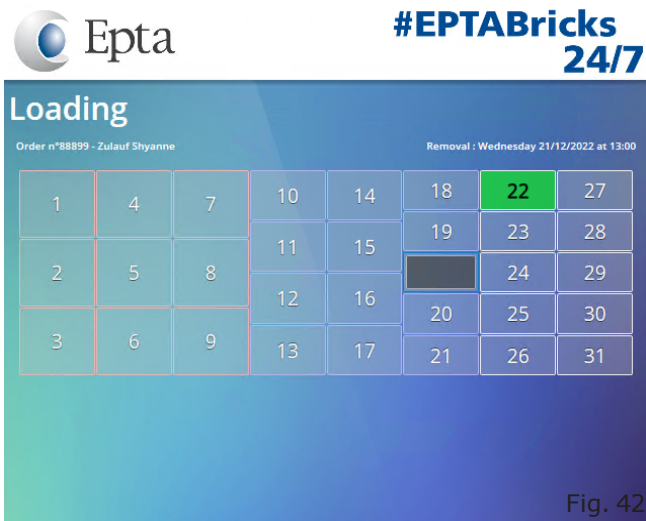

Fig. 42

- Once the doors assigned to the order have concluded, you can add further doors by pressing the key on the bottom right.



Fig. 44

- If the order requires loading of multiple doors (due to quantity or temperature requirements), on closure of the picking door, the next one will open.

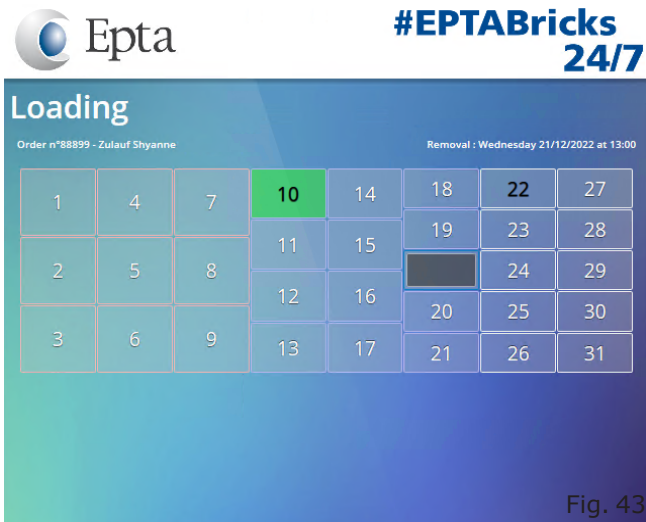

Fig. 43

- Select the type of door you want to add.

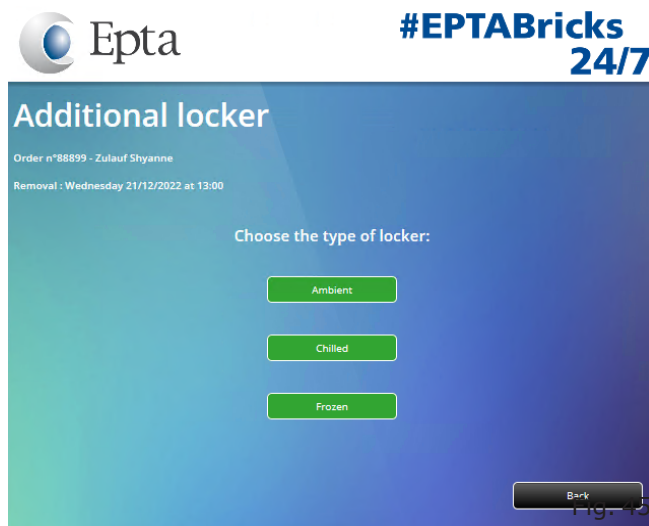
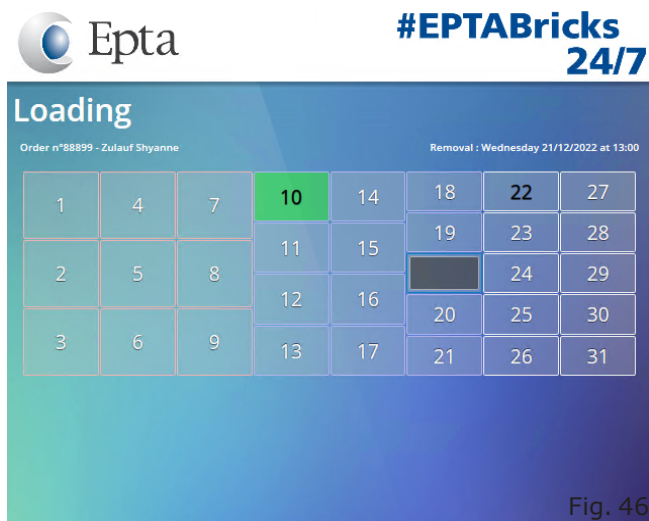

Fig. 45

Modello - Modèle - Model Modell - Modelo - Modelo	EPTABRICKS 2.0 OUTDOOR	
Fabbricante - Constructeur - Manufacturer Hersteller - Fabricante - Fabricante	Epta Spa - Via Mecenate, 86 - 20138 Milano (MI) ITALIA Tel. 02/55403211 Telefax 02/55401023	23/27

- The additional door requested will enable and open. As soon as the door is loaded, please close it.



- If you want to add another door, press the key on the bottom right again. Instead, if the goods on the order was fully loaded, press the key on the bottom left.

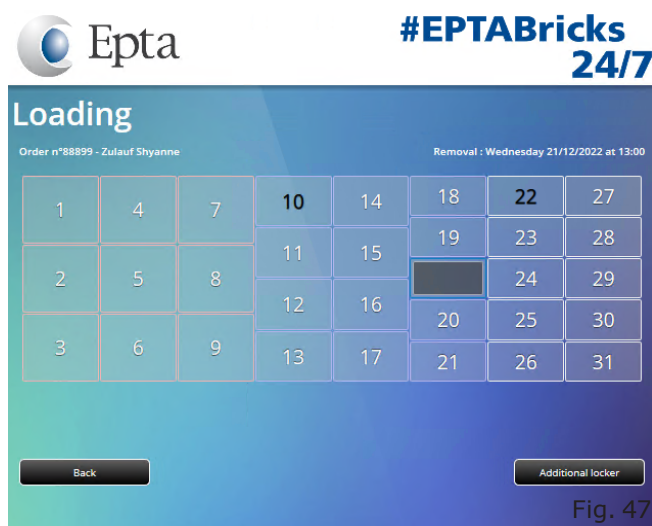

10.9 Cleaning and ordinary maintenance

Good visibility in the intervention area is recommended, possibly using an additional light source.

Cleaning the cabinet

Only use water at a maximum temperature of 65°C and household soap or neutral detergent diluted in water.

Never use:

- Abrasive sponges
- Flammable or abrasive products such as alcohol, acetone or solvents
- Detergents that contain non-ionic surfactants, lemon or vinegar (acetic acid)



Do not wash or clean the top part of the cabinet with water or liquids.

Clean all the external parts of the cabinet **ONCE A WEEK**: should be cleaned with a cloth and a neutral soap and water solution.

TOUCH SCREEN: Never use solvents of any kind, never pour water directly on the screen. Slightly dampen a cotton cloth and pass it over the screen to remove dirt or foreign bodies. Dry the screen well and pass over it with a microfibre cloth.

Clean all the internal parts of the cabinet **ONCE A MONTH**, following the instructions below:

- Disconnect the power supply to the cabinet using the wall-mounted main switch-disconnector ("Fig. 29").
- Empty the cabinet, storing the goods in cold rooms or refrigerators to maintain the preservation temperature.
- Wait for the inside of the cabinet to have reached the ambient temperature and then clean
- After carefully checking that the inside of the cabinet is completely dry, restart the appliance by re-energising the cabinet.
- After a couple of hours, load the goods again.

Modello - Modèle - Model Modell - Modelo - Modelo	EPTABRICKS 2.0 OUTDOOR	 Epta
Fabbricante - Constructeur - Manufacturer Hersteller - Fabricante - Fabricante	Epta Spa - Via Mecenate, 86 - 20138 Milano (MI) ITALIA Tel. 02/55403211 Telefax 02/55401023	24/27

User manual

IT

When you put the cabinet out of service, disconnect the power and follow the passages above, leaving the doors open (if available) to avoid odours.

FR

EN

Defrost the cabinet **EVERY THREE MONTHS** to allow the ice to melt which may have formed on the fins of the evaporator preventing correct operation. The duration of the defrosting activity is regulated directly in the factory. Any adjustments are reserved exclusively for the technical service department. The defrosting water is collected by a special drain and conveyed to a dissipation bowl placed at the bottom of the cabinet. Periodically check that the defrosting water drains normally.

DE

ES

PT

Water collection tank cleaning

Clean based on use and need and in particular environmental conditions (e.g. high humidity, low room temperature, presence of dust, etc.) to avoid incorrect and incomplete evaporation of water and/or presence of unpleasant odours.

10.10 Emergency situations

The cabinet does not start or it stops:

- Check there is no electrical blackout.
- Check that the main power switch on the wall is on.
- Check the cabinet plug is inserted into the socket.

If the power outage does not depend on these reasons, contact the nearest authorised service centre and empty completely and immediately store the product in cold rooms or refrigerators that can maintain the preservation temperature.

The cabinet does not cool sufficiently:

- Check that the condensing unit is clean and able to carry out its heat exchange function; clean thoroughly, if the fins are obstructed.
- Check that the cabinet is loading correctly.
- Defrost the cabinet and then resume normal operation, if this operation has not been carried out for more than three months.
- Check that the cabinet is not close to heat sources or air currents.
- Verify the ambient conditions; the reference values are contained in "Ambient conditions" ("Chart II").
- Check the flatness of the cabinet using a leveller.
- Check door is perfectly closed

If cooling failure persists, contact your nearest authorised service centre.

Modello - Modèle - Model Modell - Modelo - Modelo	EPTABRICKS 2.0 OUTDOOR	
Fabbricante - Constructeur - Manufacturer Hersteller - Fabricante - Fabricante	Epta Spa - Via Mecenate, 86 - 20138 Milano (MI) ITALIA Tel. 02/55403211 Telefax 02/55401023	25/27

The cabinet is noisy:

- Check screws and bolts are perfectly tightened.
- Check the flatness of the cabinet using a leveller.

If the inconvenience persists, contact your nearest authorised service centre.

10.11 Technical assistance

Where technical assistance personnel are required, contact immediately the supplier from whom the cabinet was purchased. If you need to use spare parts always refer to the technical assistance service: ask and ensure that original spare parts are used.

10.12 Dismantling and elimination

IMPORTANT INFORMATION FOR CORRECT DISPOSAL OF THE PRODUCT IN ACCORDANCE WITH EC DIRECTIVE 2012/19/UE

For reasons connected with the safeguard of the environment, and in compliance with what Directive 2011/65/EC and the relevant local national laws that establish, the cabinets for refrigerated products and frozens must be disposed of and recycled at the end of their life cycle.

Making sure that this is achieved, the user significantly helps prevent potential repercussions on the environment and on the public health.

Cabinets including a refrigerating circuit and a power plug (therefore ready to be installed) are defined WEEE: "Waste Electrical and Electronic Equipment".

- Deliver the cabinets to the appropriate centres specialising in WEEE recovery and recycling.
- Alternatively, return the cabinets to the seller or to the manufacturer.
- At any rate, collection of WEEE to be processed must be made following criteria that guarantee the protection of the cast-off appliances during transportation and during their loading and unloading. Do not leave the appliances unattended, not even for a few days.
- Avoid damaging the refrigeration circuit, as this contains fluids that may potentially be hazardous for the environment and are subject to special prescriptions.
- Make sure that doors are closed and fasten mobile parts accordingly.
- Remove the power plug from the cast-off appliances and cut off their power cord in order for them to become unusable.

The symbol appearing on the rating plate of the appliance and on the documents attached indicates that:

Modello - Modèle - Model Modell - Modelo - Modelo	EPTABRICKS 2.0 OUTDOOR	 Epta
Fabbricante - Constructeur - Manufacturer Hersteller - Fabricante - Fabricante	Epta Spa - Via Mecenate, 86 - 20138 Milano (MI) ITALIA Tel. 02/55403211 Telefax 02/55401023	26/27

User manual

IT
FR
EN
DE
ES
PT

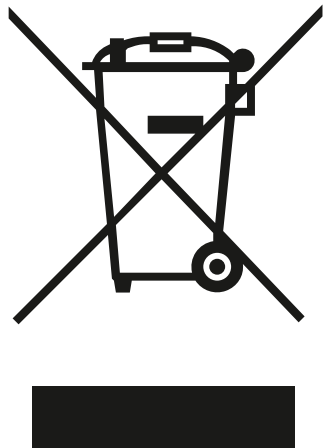

Fig. 48

- the product was issued after August 13, 2005;
- the product is subject to "separate collection", and must not be treated as household waste and cannot be delivered at a landfill.

For further details on treatment, recovery and recycling of this product, contact the relevant local office, the household waste collection service or the seller that has sold the product.

WE DECLARE THAT THE CABINET IS CONFORMING TO RoHS 2011/65/EC DIRECTIVE.



The cabinet contains oil, inflammable cooling gas, plastic and metallic components and glass. **WARNING!** Polyurethane insulation uses CICLOPENTHANE as expander, that doesn't affect the environment but is inflammable. To guarantee the same respect when it's disposed of, never abandon the equipment outside. Don't throw the packaging material from your equipment in the rubbish but sort the various materials: eg. polystyrene, cardboard, plastic bags. The demolition of the cabinet and the recovery of the component materials must be carried out according to the local regulations in force in this matter.

For out of use equipment:

- Disconnect the power supply plug.
- Remove the power supply cable and eliminate it together with the plug.
- Do not remove the drawers and various components inside the tank, to make it more difficult for children to enter the refrigerated chamber of the equipment.
- Children are forbidden from playing with the decommissioned equipment. Danger of suffocation!
- The equipment contains flammable gas inside the refrigeration circuit which must be appropriately disposed. You need to avoid damaging the refrigerating circuit when dismantling the equipment.

The components of the refrigeration circuit must not be cut and/or separated before the circuit is discharged, with the recovery of refrigerant gas by qualified personnel.

Modello - Modèle - Model Modell - Modelo - Modelo	EPTABRICKS 2.0 OUTDOOR	
Fabbricante - Constructeur - Manufacturer Hersteller - Fabricante - Fabricante	Epta Spa - Via Mecenate, 86 - 20138 Milano (MI) ITALIA Tel. 02/55403211 Telefax 02/55401023	27/27

11. SUPPLEMENTARY GENERAL WARNINGS

Instructions for correct installation and maintenance

The user and maintenance instructions are found in the User Manual available on the website:

www.eptarefrigeration.com.

The installation instructions dedicated to expert staff are available:

- From the service network
- In some categories of product in paper format delivered together with the product

Professional repair services

The services are provided by our service network which can be consulted in the contacts area at the website address www.eptarefrigeration.com.

Spare parts

The spare parts and the information for the repair of the appliance are available for at least 8 years after the product is declared out of production at the following web address: www.epta-service.com/service.

The log-in credentials are provided on request to send via mail to: servicesupport@eptarefrigeration.com.

Cleaning air condenser

The incorporated unit appliances with air condensation maintain their efficiency only if the condenser is cleaned using the methods and times indicated in the user and maintenance manual.

Important information on food waste

It is recommended to follow attentively the instructions of preservation shown in the packages of the products and the indications provided by the food producers.

Therefore, the temperature settings must be suited to the characteristics of preservation of the food products consistently in accordance with the indications set out in our technical documentation.

Incorrect uses can result in deterioration.

Ambient conditions

This appliance is intended to function in environments in which the temperature and humidity fall within the limits provided for in the User and maintenance manual.

Instructions for disassembly

For disassembly activities, it is necessary to contact the professional operators.

Epta group has always been driven by a particular attention to the environment. It makes available to users the manuals for dismantling and treating the waste of the plug-in refrigerated cabinets, which can be downloaded below.

- Manual for dismantling open plug-in cabinets:



- Manual for dismantling closed plug-in cabinets:



Other information

For further and more detailed information, please refer to www.eptarefrigeration.com and to EPREL which is accessed through the QR code here or in the energy label of the product.



Modello - Modèle - Model Modell - Modelo - Modelo	EPTABRICKS 2.0 OUTDOOR	
Fabbricante - Constructeur - Manufacturer Hersteller - Fabricante - Fabricante	Epta Spa - Via Mecenate, 86 - 20138 Milano (MI) ITALIA Tel. 02/55403211 Telefax 02/55401023	1/3

IT

FR

EN

DE

ES

PT

Modello - Modèle - Model Modell - Modelo - Modelo	EPTABRICKS 2.0 OUTDOOR	
Fabbricante - Constructeur - Manufacturer Hersteller - Fabricante - Fabricante	Epta Spa - Via Mecenate, 86 - 20138 Milano (MI) ITALIA Tel. 02/55403211 Telefax 02/55401023	2/3

User manual

- IT
- FR
- EN
- DE
- ES
- PT

